

Schneider GLOW D2W

Montage-Anleitung

Instructions de montage

Assembling instructions

Typ

GLO1 50/1/D2W/L
 GLO1 50/1/D2W/R
 GLO1 60/1/D2W/L
 GLO1 60/1/D2W/R
 GLO1 60/2/D2W/L
 GLO1 60/2/D2W/R
 GLO1 80/2/D2W
 GLO1 90/2/D2W
 GLO1 100/2/D2W
 GLO1 120/2/D2W
 GLO1 120/3/D2W
 GLO1 130/2/D2W
 GLO1 130/3/GT/D2W
 GLO1 140/3/GT/D2W
 GLO1 150/3/GT/D2W
 GLO1 160/3/GT/D2W
 GLO1 180/3/GT/D2W

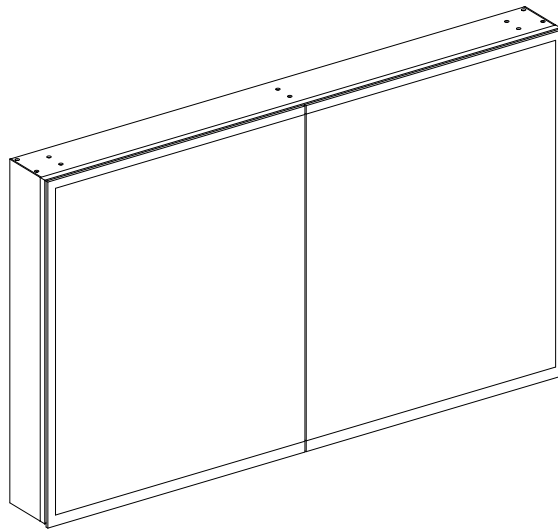

Technische Daten / Caractéristiques techniques/ Technical data

Nennspannung / Tension nominale / Nominal voltage	230 V ~
Betriebsspannung / Tension de service / Operating voltage	24 V ===
Netzfrequenz / Fréquence du réseau/ Mains frequency	50 Hz
Lichtfarbe / Couleur de la lumière / Light colour	2000-6500 K
Schutzart / Type de protection / Protection type	IP 44
Schutzklasse / Classe de protection/ Protection class	I
Steckertyp Steckdose Schweiz / Type de fiche prise Suisse / Plug type socket Switzerland	SEV T13
Steckertyp Steckdose Europa / Type de fiche prise Europe / Plug type socket Europe	CEE 7/3 (Schuko)
Steckertyp Steckdose Grossbritannien / Type de fiche prise Grande-Bretagne / Plug type socket Great Britain	BS 4573 (shaver socket)
Netzspannung Steckdose(n) / Tension du réseau prise(s) électrique / Mains voltage socket(s) outlet	230 V ~
Steckdose(n) I _{max} / Prise(s) I _{max} / socket(s) I _{max}	9 A / 2070 W
Bemessungsstrom / Courant nominal / Nominal current	10 A
Betriebsfrequenz Funk / Fréquence de fonctionnement radio / Operating frequency radio	2400 - 2483, 5 MHz
Maximale Sendeleistung Funk / Puissance d'émission maximale radio / Maximum transmission power radio	0 dBm
Energieeffizienzklasse Lichtquellen / Classe d'efficacité énergétique sources lumineuses / Energy efficiency class light sources	C
Batterietyp / Type de batterie / Battery type	CR2032

Lieferumfang / Contenu de la livraison / Scope of delivery

- Spiegelschrank / Armoire-miroir / Mirror cabinet
- Aufhängeschiene / Rail de suspension / Suspension rail
- Schraubenset / Jeu de vis / Set of screws
- Glastablare / Tablettes en verre / Glass shelves:

2 Stk/pcs	(50/1, 60/1, 60/2)
4 Stk/pcs	(80/2, 90/2, 100/2, 120/2, 120/3, 130/2, 130/3, 140/3, 150/3)
6 Stk/pcs	(160/3, 180/3)

Schneider GLOW D2W



Arbeiten an den elektrischen Anlagen dürfen nur von autorisierten Fachleuten nach den örtlichen Vorschriften ausgeführt werden. Für nicht fachgerechte Installation wird jegliche Haftung abgelehnt.

Les travaux à l'installation électrique ne doivent être effectués que par des spécialistes autorisés selon les prescriptions locales. Si l'installation n'est pas faite par un expert nous déclinons toute responsabilité.

Electric installation work may only be carried out by approved specialists according to the local regulations. Liability will only be accepted by us when our products are installed by qualified engineers.



Räume mit Badewanne oder Dusche müssen mit einer FI-Schutzeinrichtung (RCD) I $\Delta n = 30$ mA gesichert sein. Bereich 2 mindestens Schutzart IP X4. Bereich 2 keine Steckdosen.

Locaux avec baignoire ou douche doivent être protégés par un dispositif de protection FI (RCD) I $\Delta n = 30$ mA. Volume 2 min. degré de protection IP X4. Volume 2 des prises électriques ne sont pas permis.

Rooms with bath or shower have to be protected with residual-current-operated protective device FI (RCD) I $\Delta n = 30$ mA. Volume 2 min. protection IP X4. Volume 2 no socket admitted.

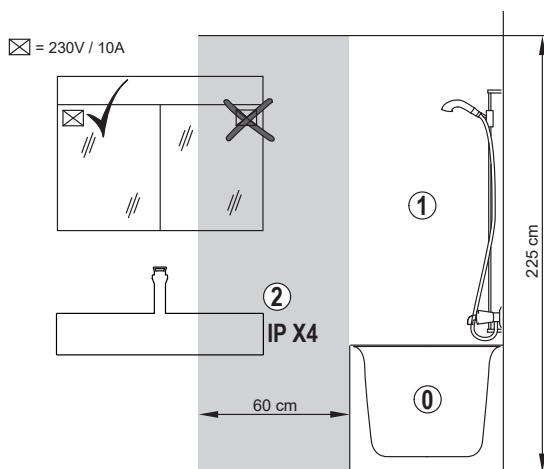

SEV NIN 2015 1000 - 7.01



VDE 0100 - 701



BS 7671 - 601



NEN 1010



Werfen Sie Ihr Produkt, wenn es ausgedient hat, im Interesse des Umweltschutzes nicht in den Hausmüll, sondern führen Sie es einer fachgerechten Entsorgung zu.



Dans l'intérêt de la protection de l'environnement, ne jetez pas votre produit avec les ordures ménagères lorsqu'il est hors d'usage. Le mettre au rebut de manière appropriée.

In the interests of environmental protection, do not dispose of your product with household waste when it has reached the end of its service life, but dispose of it properly



Eignet sich nur für Innenräume.
Uniquement montage intérieur.
Indoor installation only.

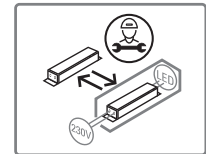
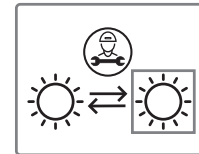

Die Lichtquellen und elektronischen Bauteile sind gemäss Artikel 4 der EU-Verordnung 2019/2020 durch den Hersteller oder eine Fachperson auswechselbar.

Les sources lumineuses et les composants électroniques sont remplaçables par le fabricant ou par une personne qualifiée, conformément à l'article 4 du règlement EU 2019/2020.

The light sources and electronic components are replaceable by the manufacturer, or by a qualified person in accordance with Article 4 of EU Regulation 2019/2020.



Dieses Produkt erfüllt die Anforderungen der geltenden europäischen und nationalen Richtlinien. Die Konformität wurde nachgewiesen. Entsprechende Erklärungen und Unterlagen sind beim Hersteller hinterlegt.

Ce produit répond aux exigences des directives européennes et nationales en vigueur. La conformité a été prouvée. Les déclarations et documents correspondants sont déposés auprès du fabricant.

This product fulfils the requirements of the applicable European and national directives. Conformity has been verified. Corresponding declarations and documents are available from the manufacturer.

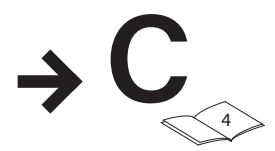
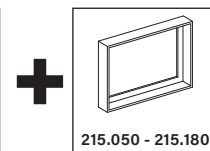
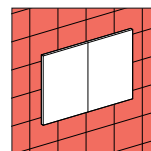
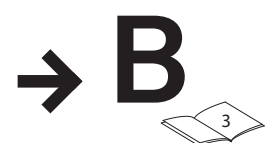
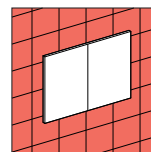
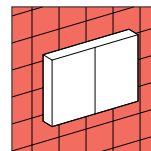

Schneider GLOW D2W

1



Vor dem Beginn vom Netz trennen.

Au début séparer du réseau.

Turn off electricity before beginning.



Spiegeltüren vor Einbau entfernen.

Démonter les portes miroirs avant la pose.

Remove mirror doors before installation.

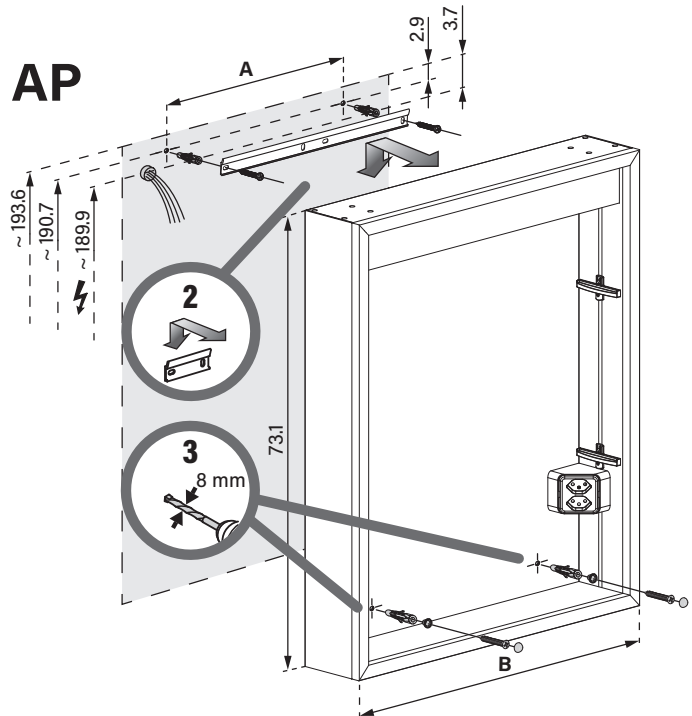
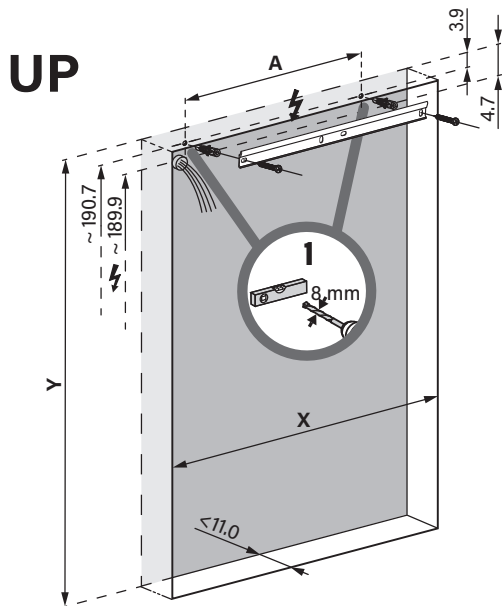
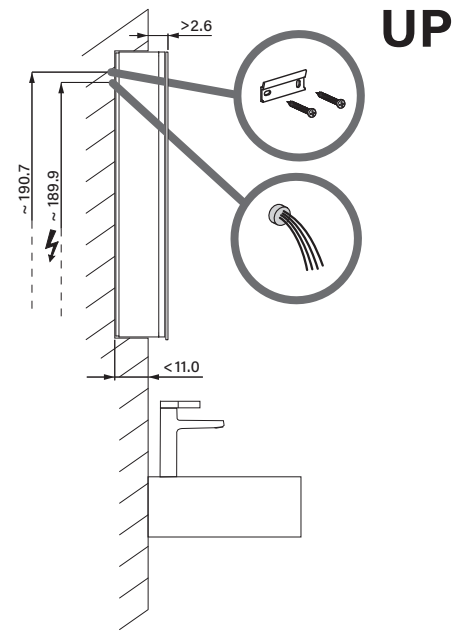
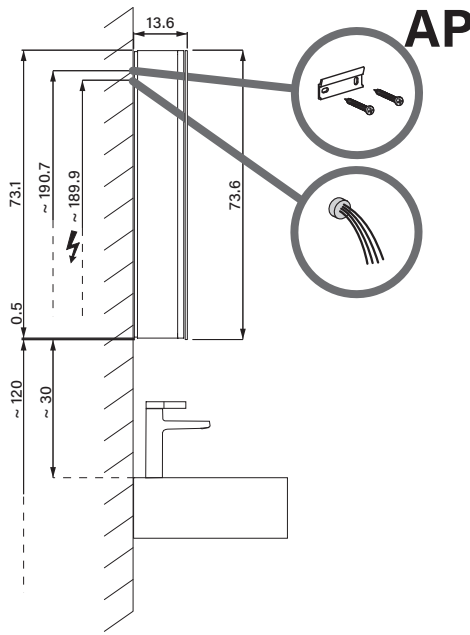



Nischengröße und Befestigung sind bau-seits zu bestimmen.

La taille de la niche et la fixation doivent être déterminées sur place par le client.

The recess dimensions and the fixing system will need to be determined on site.

GLO1	A	B
50..	35	49.5
60..	35	59.5
80..	55	79.5
90..	65	89.5
100..	65	99.5
120..	95	119.5
130..	95	129.5
140..	95	139.5
150..	125	149.5
160..	125	159.5
180..	125	179.5

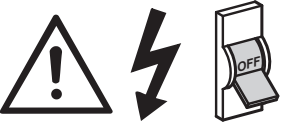
Schneider GLOW D2W



Vor dem Beginn vom Netz trennen.

Au début séparer du réseau.

Turn off electricity before beginning.



Spiegeltüren vor Einbau entfernen.

Démonter les portes miroirs avant la pose.

Remove mirror doors before installation.

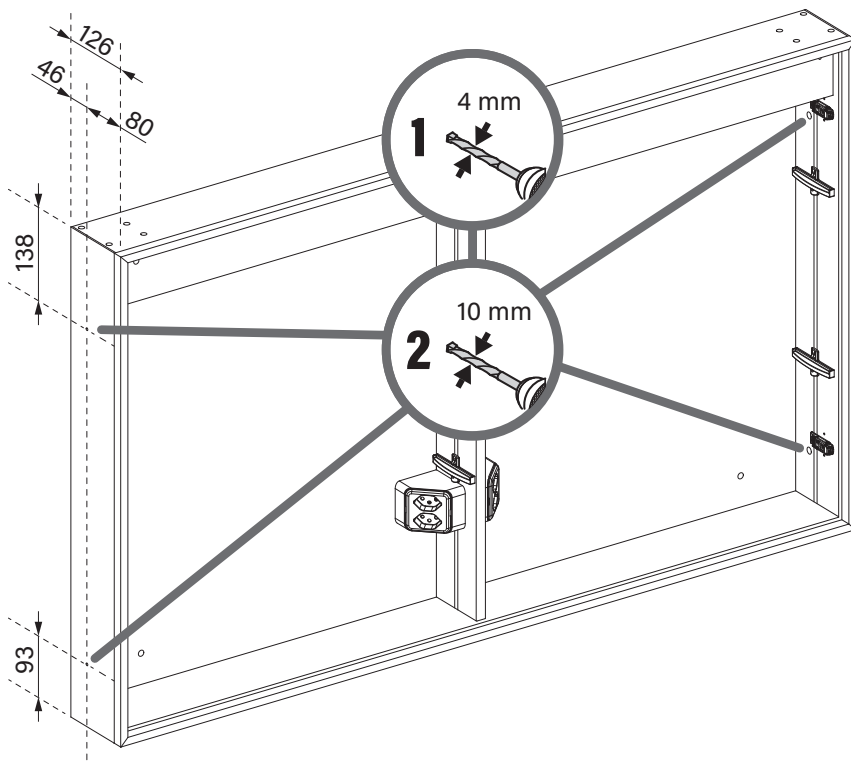
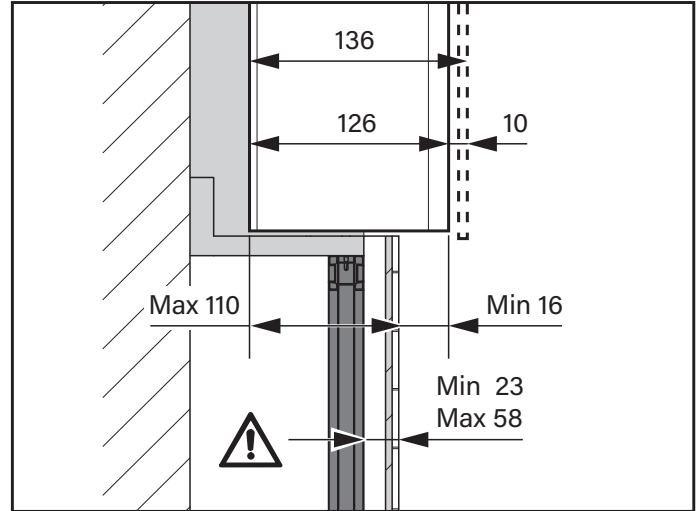

Diese Montage ohne Winkelstücke, nur mit Unterlagsplättchen.

Cet assemblage sans coudes, uniquement avec embases.

This assembly without elbows, only with base plates.

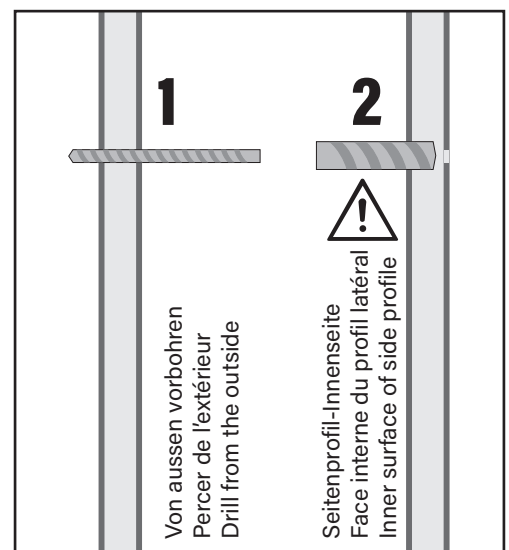

Nicht in elektronische Teile bohren!
Ne percez pas dans des pièces électroniques!
Do not drill into electronic parts!

Schneider GLOW D2W

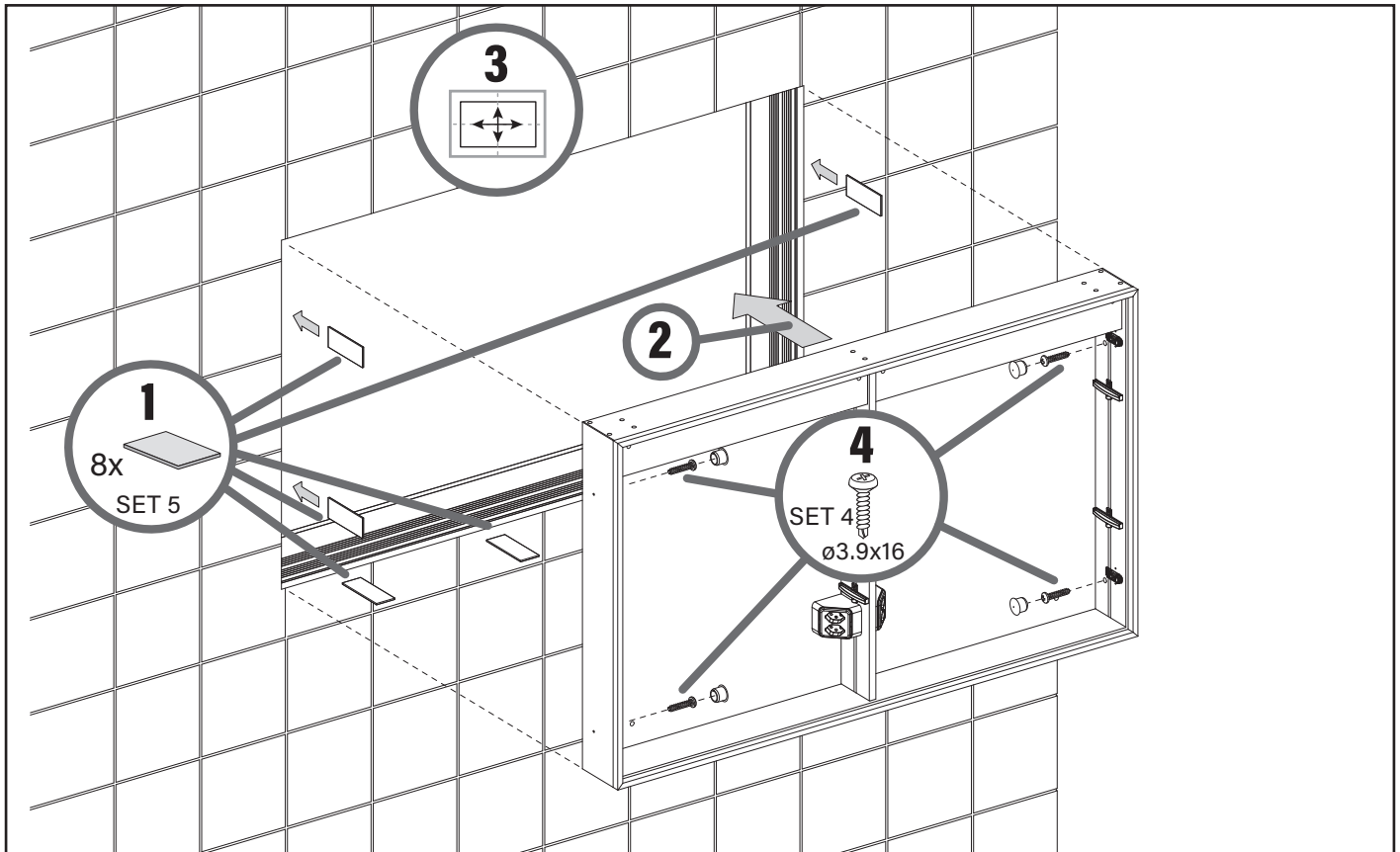

2

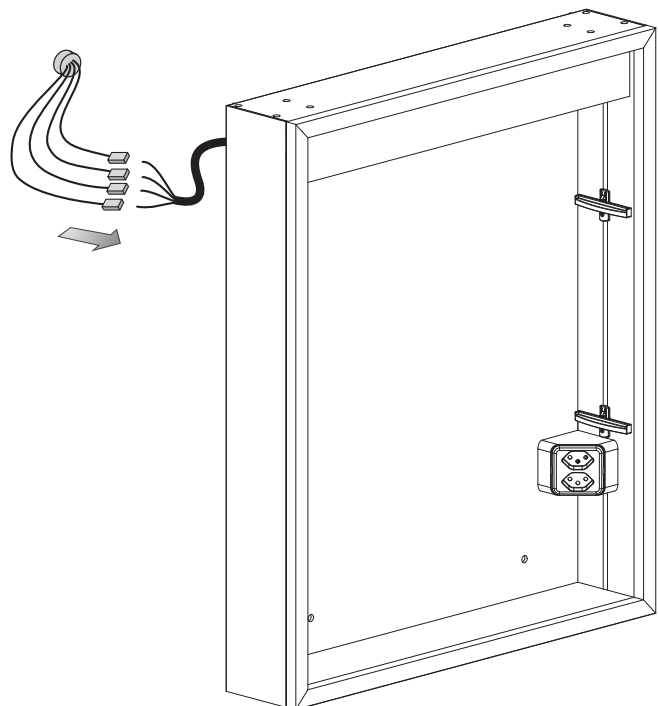
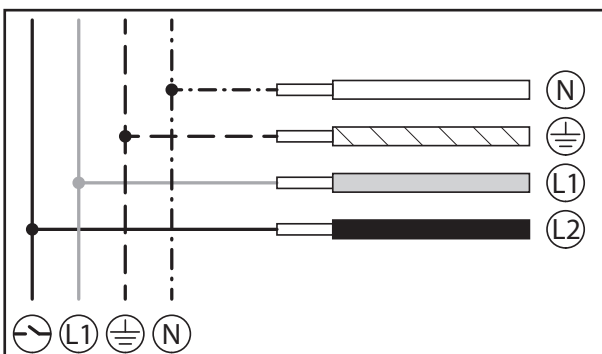
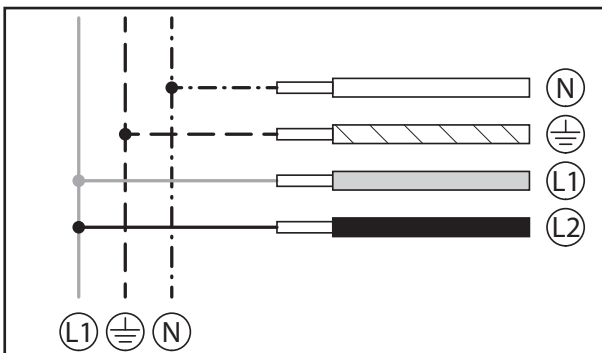

Schneider GLOW D2W

3

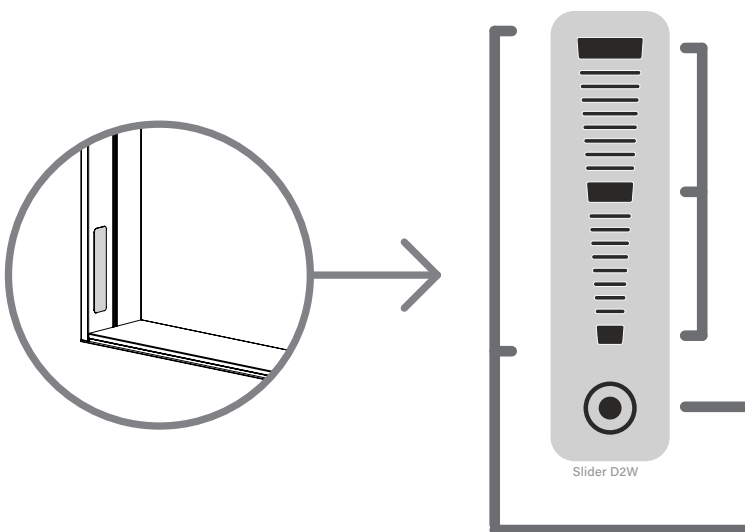
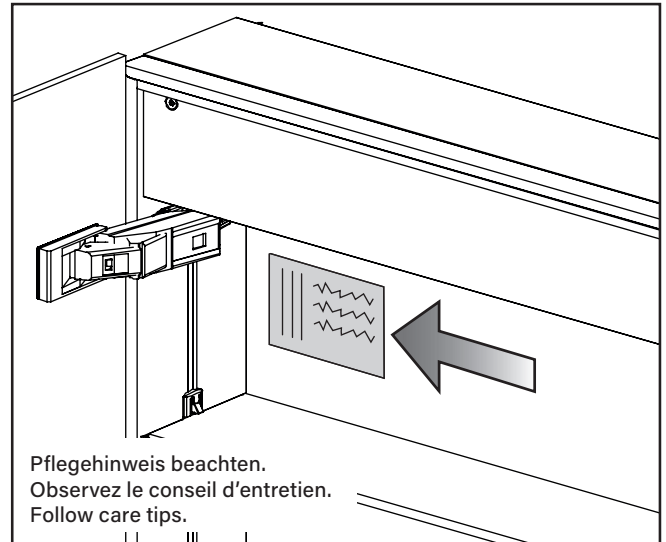
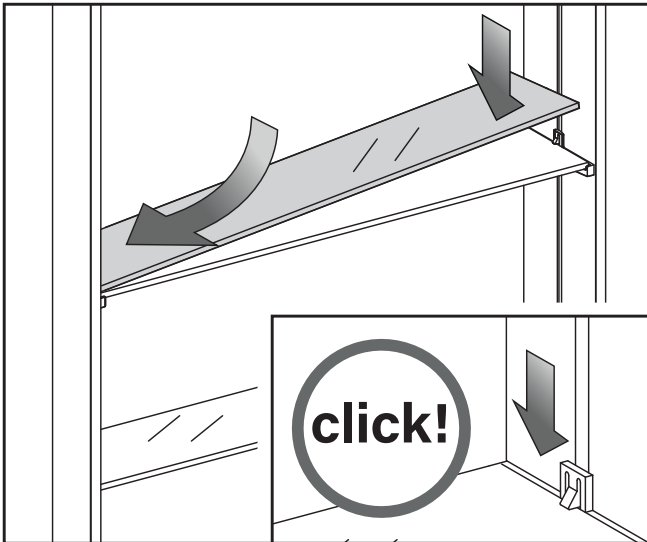
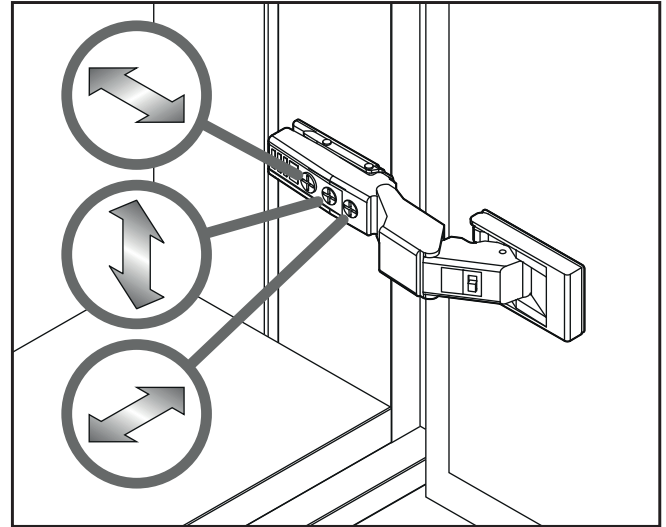
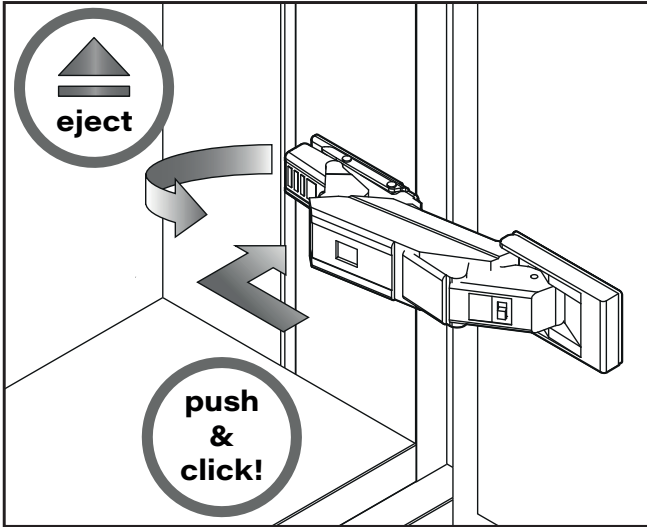

Kurz Andrücken _____ Lichtszenen-Voreinstellung
abrufen (I - III)
Appuyer brièvement _____ Appeler le pré réglage des
scènes lumineuses (I - III)
Short press _____ Recall light scene preset (I - III)

Lichtquelle _____ ein / aus
Illumination _____ allumée / éteinte
Lighting _____ on / off

Drücken und ziehen _____ Dimmen + Lichttemperatur
Appuyer et glisser _____ Varier l'intensité + température de
Press and slide _____ Dim + light temperature