

DE Montageanleitung**EN** Mounting instruction**ES** Instrucciones de instalación**FR** Instructions d'installation**IT** Istruzioni per l'installazione**NL** Montagehandleiding**CS** Návod k instalaci**PL** Instrukcja montażu**RU** Инструкция по монтажу

59557 010001 59557 030001
 59557 050001 59557 070001
 59557 130001 59557 170001
 59557 370001

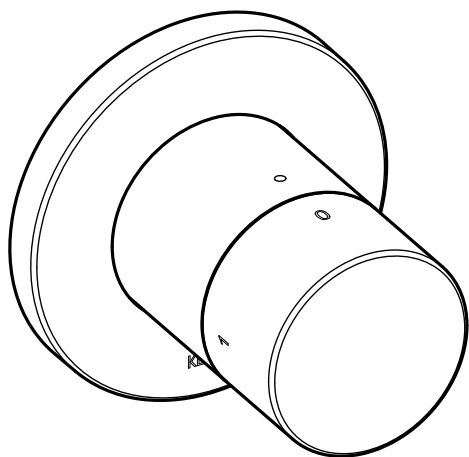

59557 010002 59557 030002
 59557 050002 59557 070002
 59557 130002 59557 170002
 59557 370002

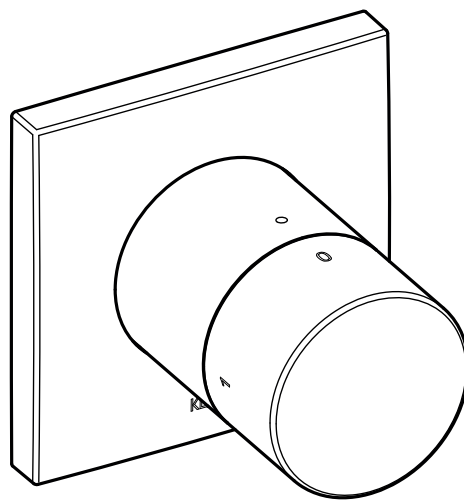
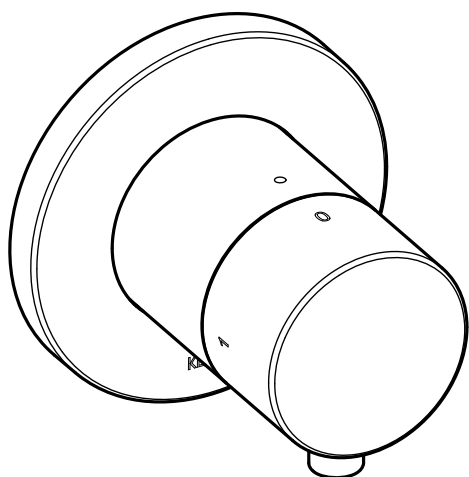

59557 011001 59557 031001
 59557 051001 59557 071001
 59557 131001 59557 171001
 59557 371001

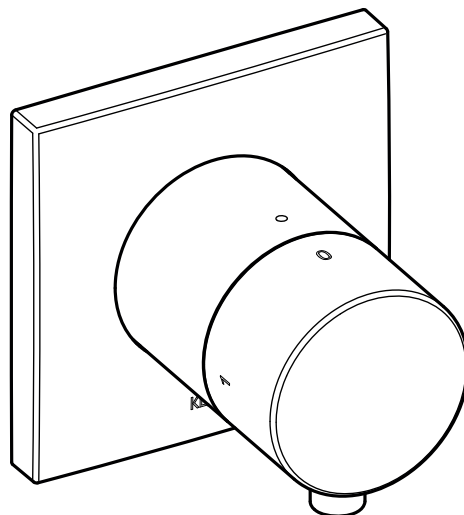

59557 011002 59557 031002
 59557 051002 59557 071002
 59557 131002 59557 171002
 59557 371002

DE Einbaumaße

FR Cotes de montage

CS Montážní rozměry

EN Mounting dimensions

IT Ingombro

PL Wymiary montażowe

ES Dimensiones de montaje

NL Montageafmetingen



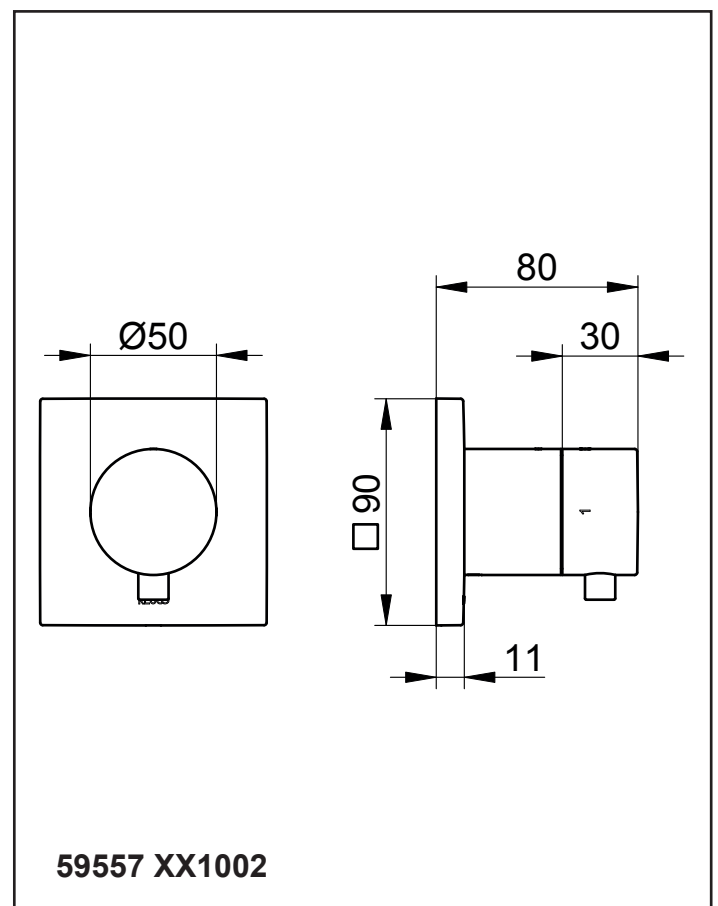
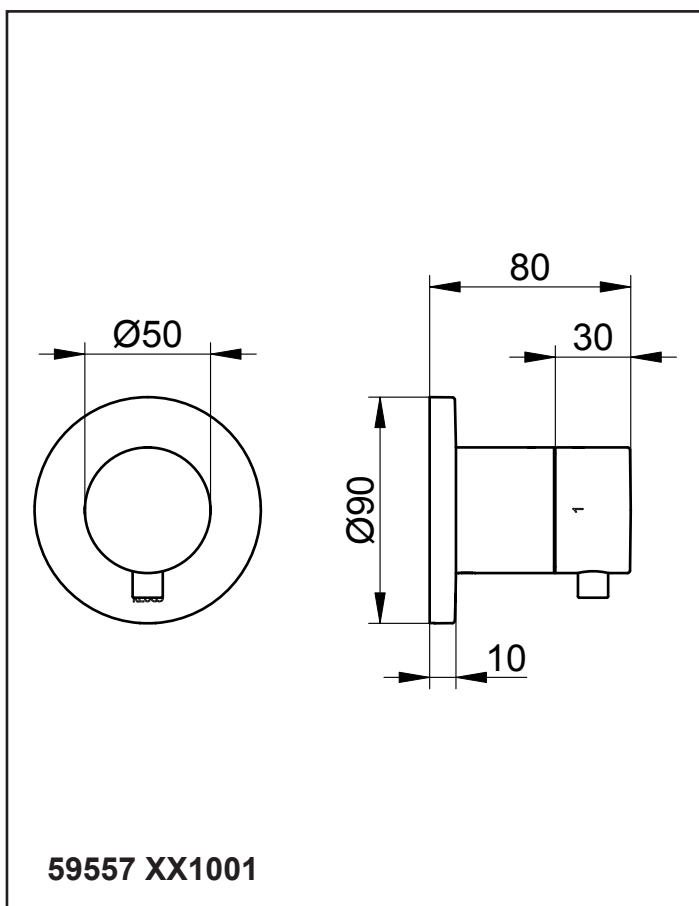
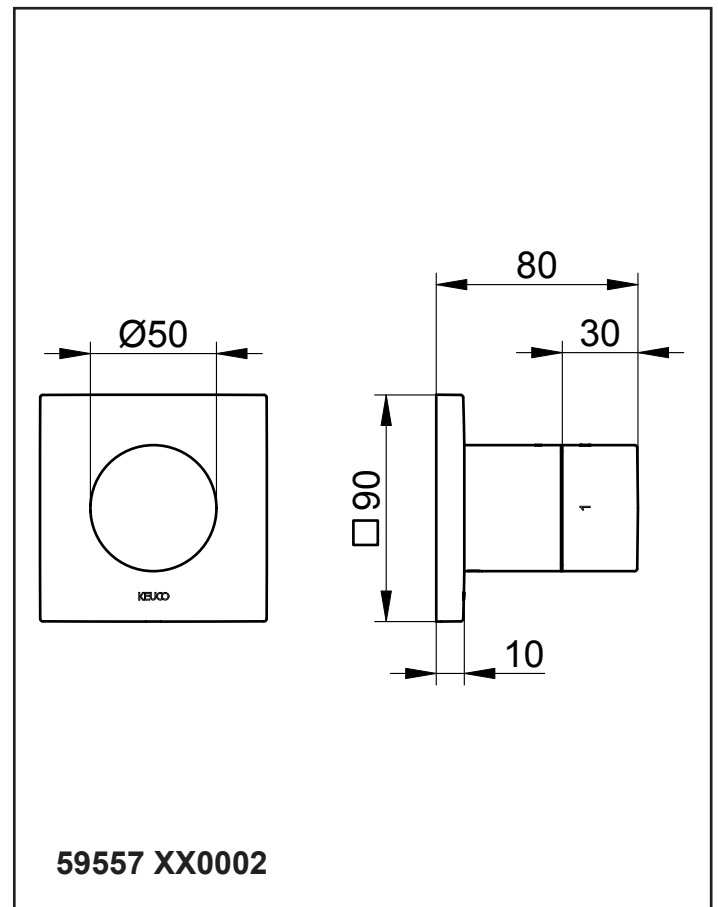
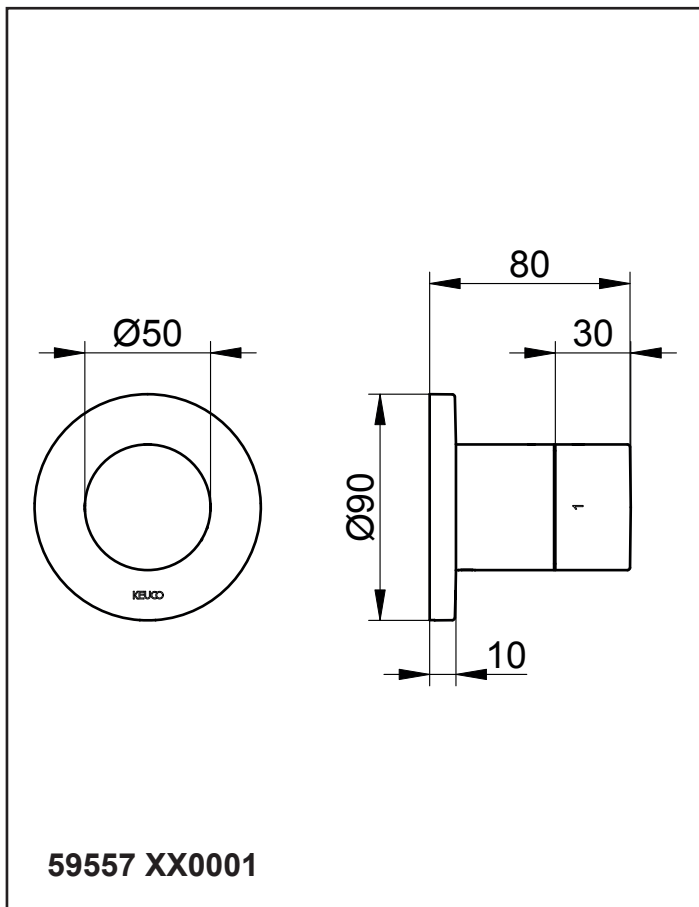





RU Монтажные размеры













 Diese Anleitung ist für den Installateur zur Montage sowie für den Nutzer zur Bedienung und Wartung des Produktes. Bitte nach der Installation an den Nutzer zur Verwahrung weitergeben.

 These instructions are for both the installer for installation and the user for operation and maintenance of the product. After installation, please hand them over to the user to keep.

Symbole und Bedeutung

-  **Achtung!** Warnung vor Personen- oder Sachschaden.
-  Hinweis, Tipp oder Verweis
-  Korrekte Montage/Funktionsprüfung
-  Falsche Montage
-  Montagedetail beachten
-  Kaltwasser  Warmwasser
-  Wasserfluss  Kein Wasserfluss
-  Optional/Zubehör

Symbols and explanations

-  **Attention!** Warning against bodily injury or damage to property.
-  Note, tip or reference
-  Correct installation/test of functionality
-  Incorrect installation
-  Observe installation details
-  Cold water  Hot water
-  Water flow  No water flow
-  Optional/accessories

Technische Daten

Durchfluss bei 3 bar Fließdruck
– Ausgang 1: ca. 26 l/min
– Ausgang 2: ca. 23 l/min

Technical specifications

Flow at 3 bar pressure
– Outlet 1: approx. 26 l/min
– Outlet 2: approx. 23 l/min

Einbaumaße, siehe Seite 2

Installation dimensions, refer to page 2

Installation, siehe ab Bild 1 auf Seite 8

 Nur neutral vernetzendes Silikon verwenden.

Installation, refer to picture 1 on page 8

 Use only neutrally netting silicone.

Bedienung, siehe Bild 11 auf Seite 10

Operation, refer to picture 11 on page 10

Wartung, siehe Bild 12 auf Seite 10

Montage in umgekehrter Reihenfolge.
– Anzugsmoment Kartuschenmutter: 20-30 Nm

Servicing, refer to picture 12 on page 10

Assemble in reverse order.
– Cartridge nut torque: 20-30 Nm

Ersatzteile mit Bestellnummern, siehe Seite 11

For spare parts with order numbers, refer to page 11

 Hinweise zur Gewährleistung und Pflege sind dem beiliegendem **Pflege- und Garantiepass** zu entnehmen.

 For warranty and care information please refer to the attached **warranty and care instructions**.

 Il presente manuale è indirizzato agli installatori per il montaggio nonché agli utilizzatori per l'uso e la manutenzione del prodotto. Consegnarlo all'utilizzatore dopo l'installazione affinché lo custodisca.

Simboli e significato

 **Attenzione!** Pericolo di lesioni o danni materiali.



 Avvertenza, consiglio o rimando

 Montaggio corretto/verifica del funzionamento

 Montaggio errato

 Prestare attenzione al dettaglio di montaggio

 Acqua fredda  Acqua calda

 Flusso d'acqua  Nessun flusso d'acqua

 Opzionale/accessorio

Dati tecnici

Portata con pressione di flusso di 3 bar
 – Allacciamento 1: circa 26 l/min
 – Allacciamento 2: circa 23 l/min

Ingombro, vedi pagina 2

Installazione, vedi dalla figura 1 a pagina 8

 Utilizzare solo silicone neutro.

Uso, vedi figura 11 a pagina 10

Manutenzione, vedi figura 12 a pagina 10

Eseguire il montaggio in ordine inverso.
 – Coppia del dado della cartuccia: 20-30 Nm

Ricambi con numero d'ordine, vedi pagina 11

 Indicazioni relative alla garanzia e al trattamento vanno desunte dalla **scheda allegata**.

 Deze handleiding is bestemd voor zowel de installateur voor de montage alsook voor de gebruiker voor het gebruik en het onderhoud van het product. Gelieve na de installatie door te geven aan de gebruiker om te bewaren.

Symbolen en betekenis

 **Opgepast!** Gevaar voor letsel of schade.

 Opmerking, tip of referentie

 Correcte montage/werkingstest

 Verkeerde montage

 Montagedetails in acht nemen

 Koud water  Heet water

 Waterstroom  Geen waterstroom

 Optioneel/toebehoren

Technische gegevens

Doorstroming bij 3 bar stromingsdruk:
 – Ansluiting 1: ca. 26 l/min
 – Ansluiting 2: ca. 23 l/min

Inbouwafmetingen, zie pagina 2

Installatie, zie vanaf afbeelding 1 op pagina 8

 Uitsluitend neutraal vernette siliconen gebruiken.

Gebruik, zie afbeelding 11 op pagina 10

Onderhoud, zie afbeelding 12 op pagina 10

Montage in omgekeerde volgorde.
 – Aandraaimoment moer voor cartouche: 20-30 Nm

Wisselstukken met bestelnummers, zie pagina 11

 Instructies voor de waarborg en het onderhoud vindt u in de meegeleverde **Onderhouds- en garantietaal**.

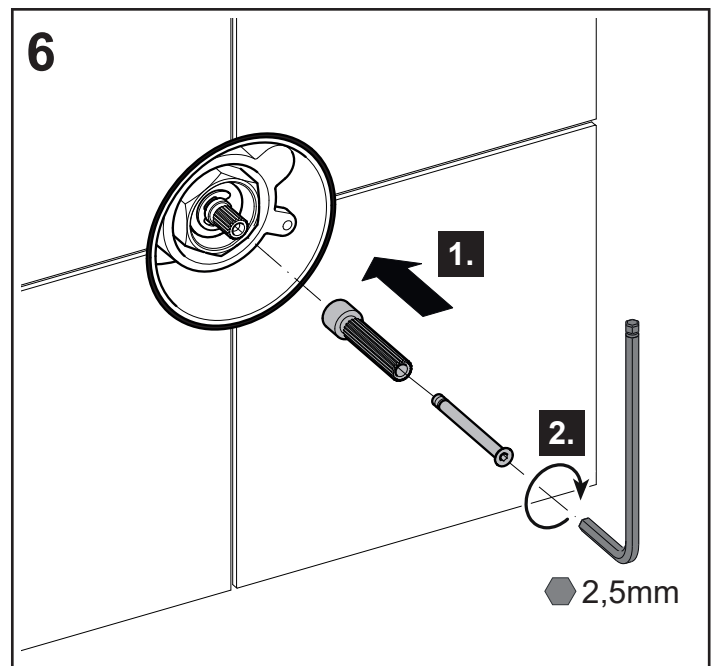
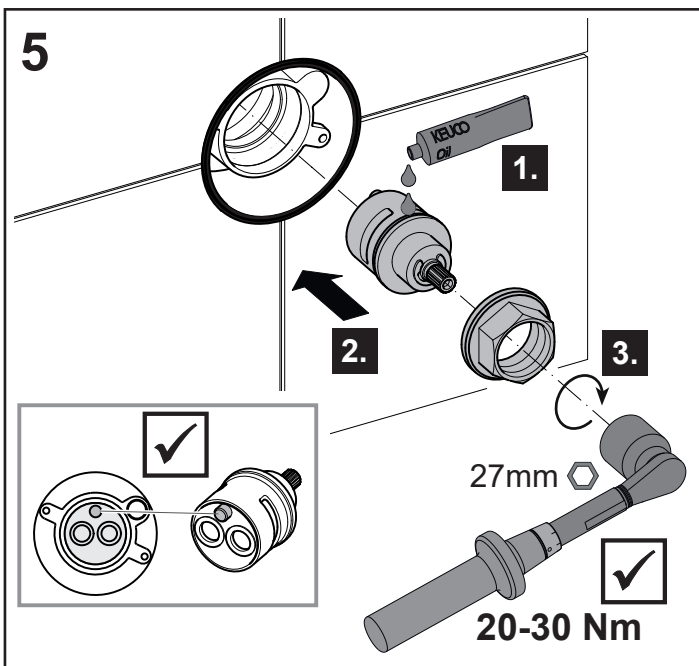
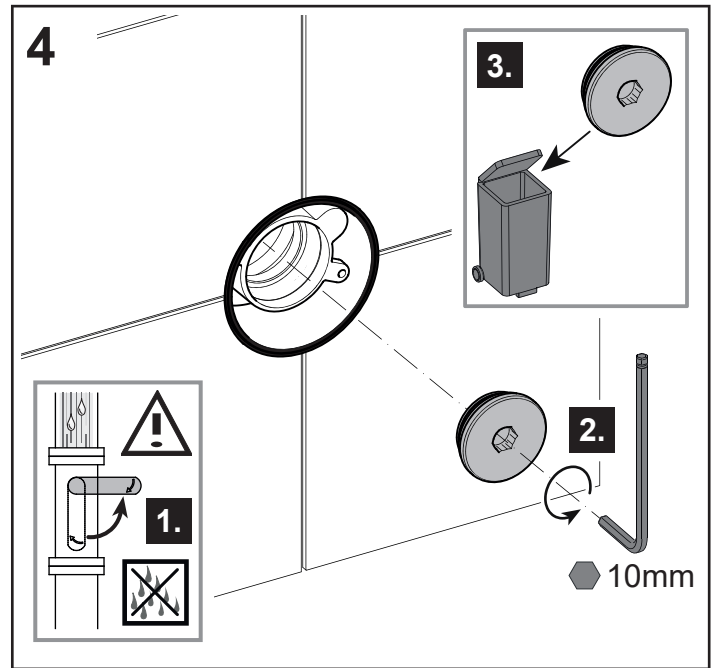
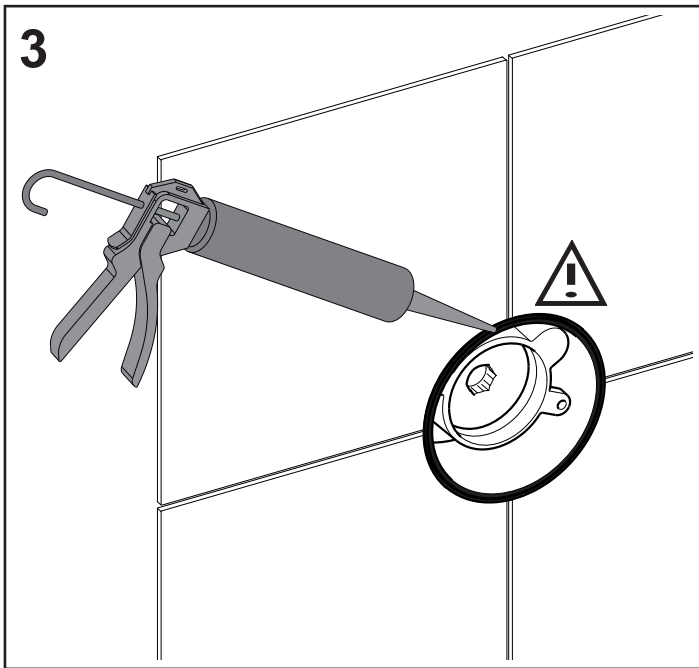
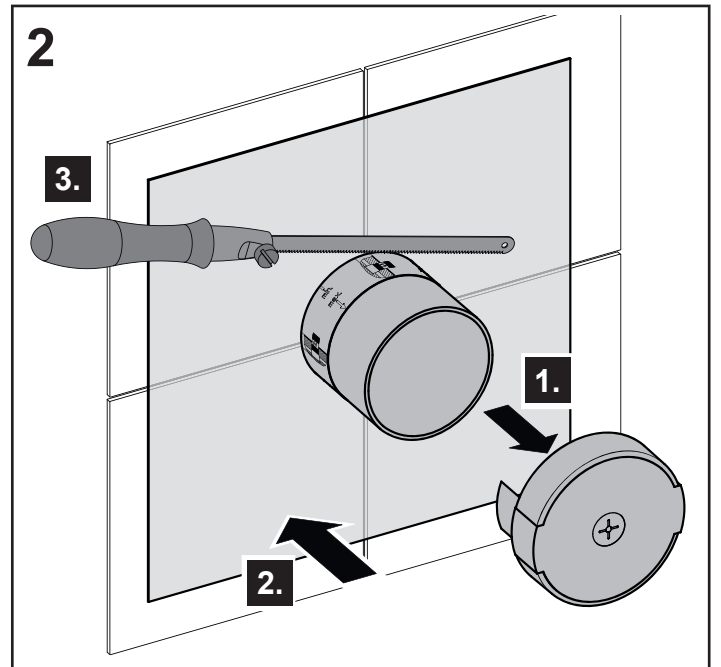
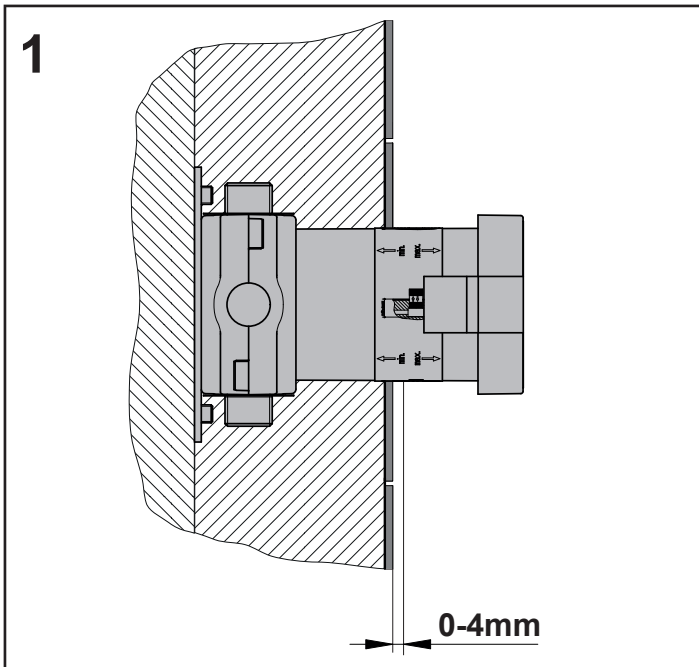

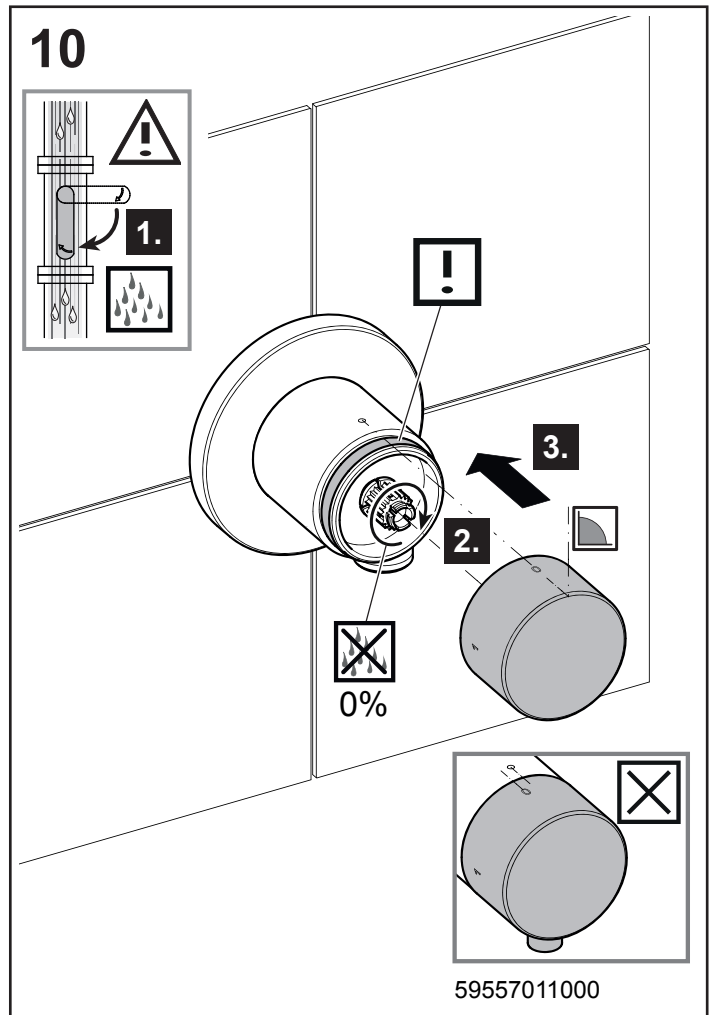
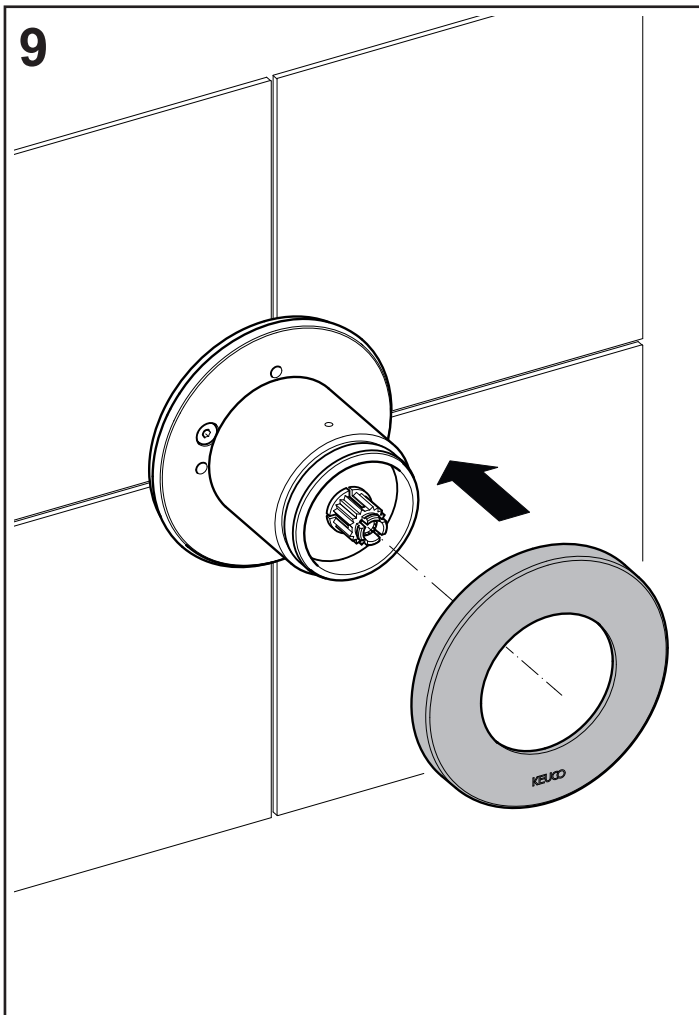
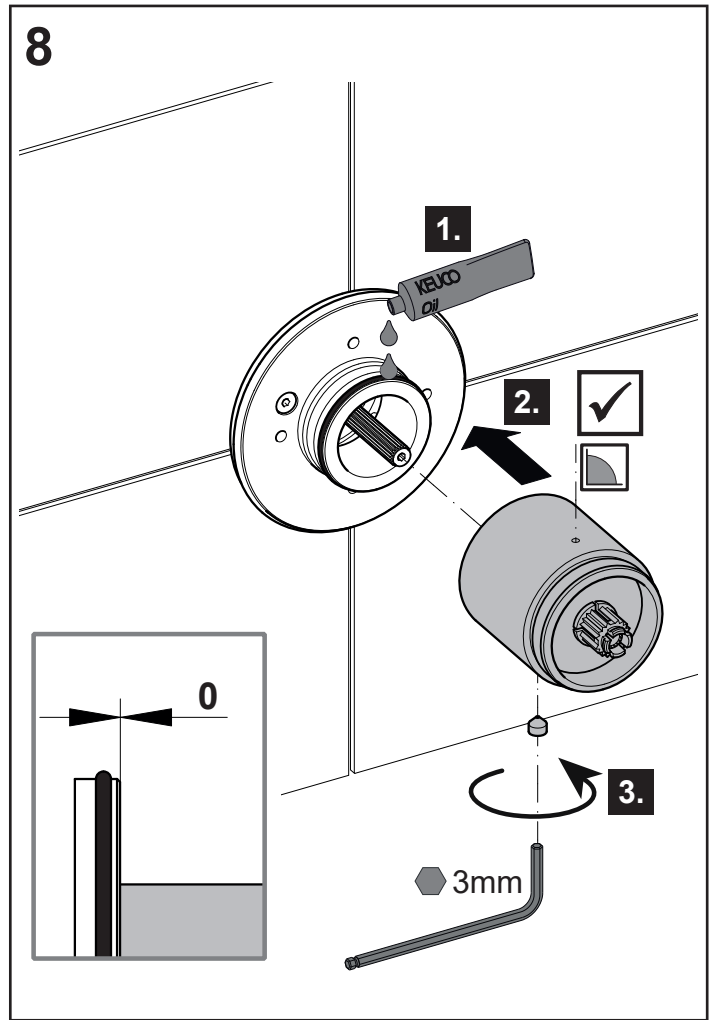
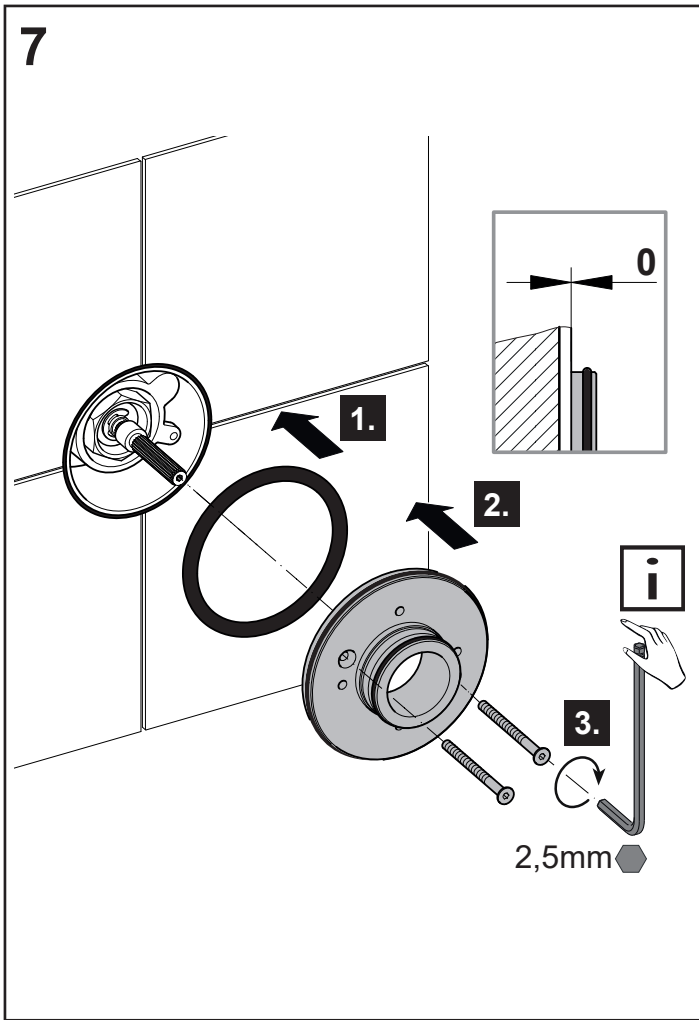

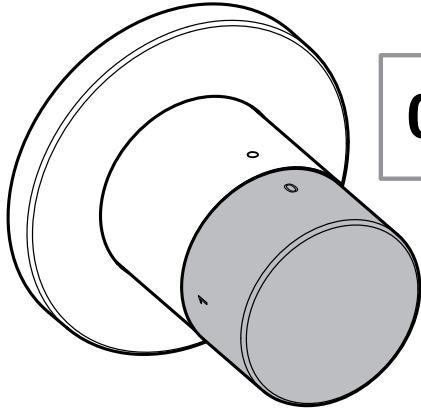

11

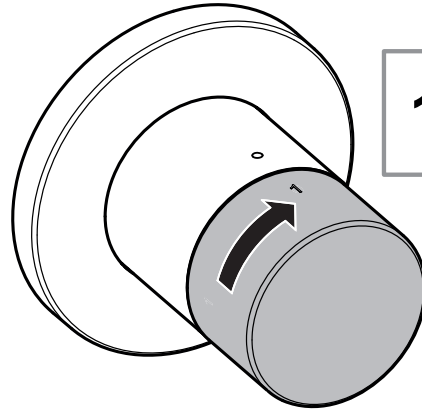

0 
0%



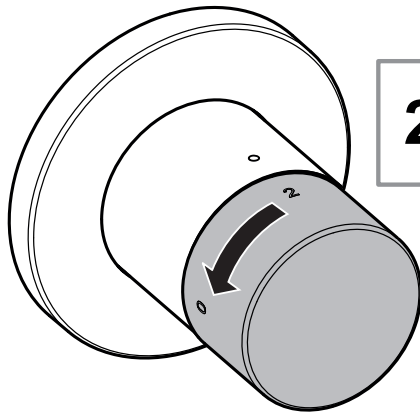

1 
100%

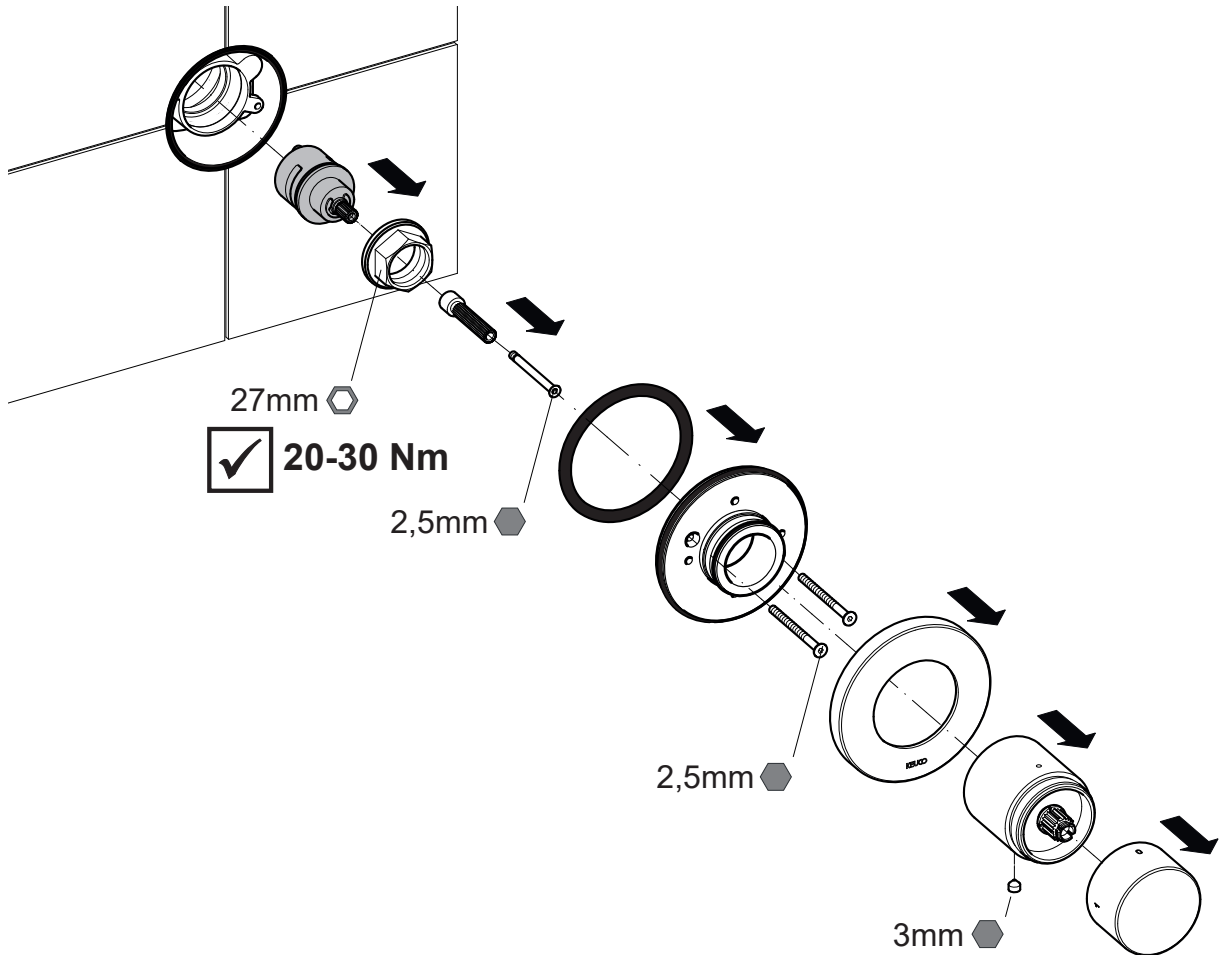

2 
100%

12



27mm 

20-30 Nm

2,5mm 

2,5mm 

3mm 

DE Ersatzteile

FR Pièces de rechange

CS Náhradní díly

EN Spare parts

IT Ricambi

PL Części zamienne

ES Piezas de recambio

NL Reserveonderdelen

RU Запчасти

