

# PLANOX

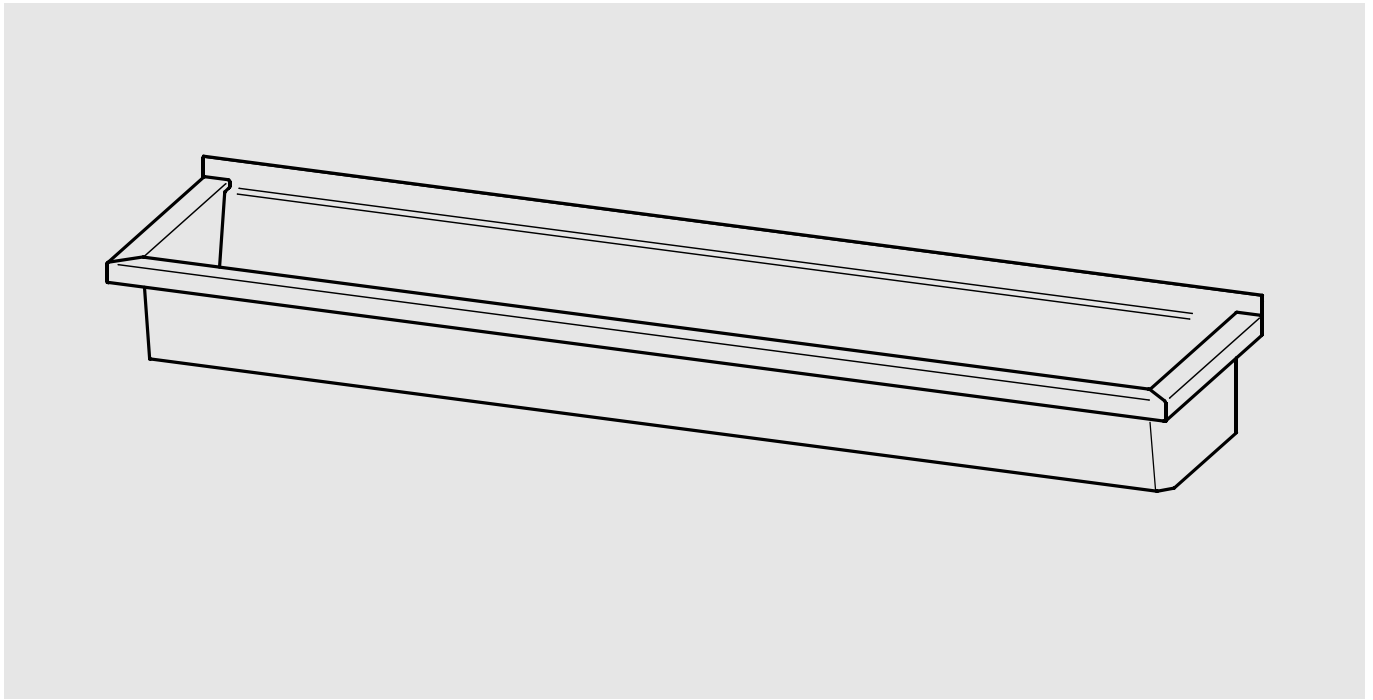

DE	Montage- und Betriebsanleitung	Waschrinne
EN	Installation and operating instructions	Wash trough
FR	Notice de montage et de mise en service	Lavabo rigole
ES	Instrucciones de montaje y servicio	Lavamanos colectivo
IT	Istruzioni per il montaggio e l'uso	Lavello a canale
NL	Montage- en bedrijfsinstructies	Wasgoot
PL	Instrukcja montażu i obsługi	Umywalka szeregową
SV	Monterings- och driftinstruktion	Radvättställ
CS	Návod pro montáž a provoz	Mycí koryto
FI	Asennus- ja käyttöohje	Sarjapesuallas
RU	Инструкция по монтажу и вводу в эксплуатацию	

**PL6**  
2030043777  
600×210×382 mm

**PL8**  
2030043778  
800×210×382 mm

**PL10**  
2030046721  
1000×210×382 mm

**PL12**  
2030043779  
1200×210×382 mm

**PL14**  
2030046728  
1400×210×382 mm

**PL16**  
2030043780  
1600×210×382 mm

**PL18**  
2030043781  
1800×210×382 mm

**PL21**  
2030046734  
2100×210×382 mm

**PL24**  
2030043782  
2400×210×382 mm

**PL28**  
2030046736  
2800×210×382 mm

**PL30**  
2030043783  
3000×210×382 mm

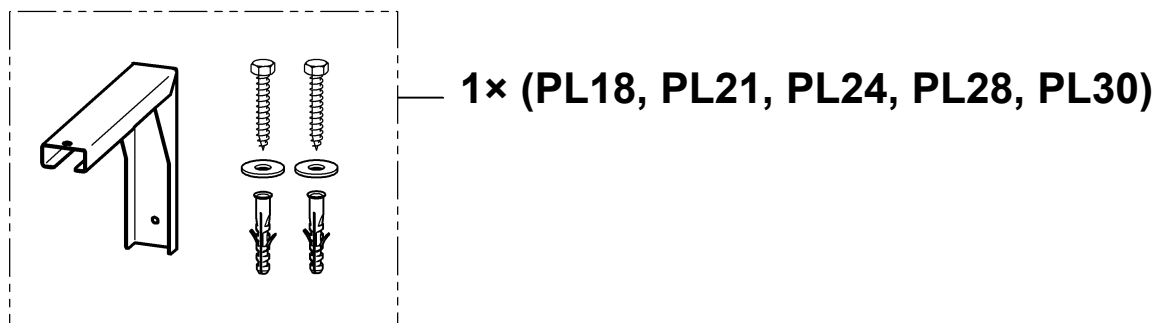
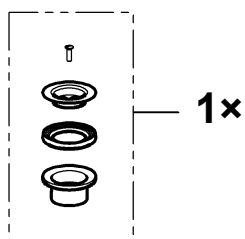
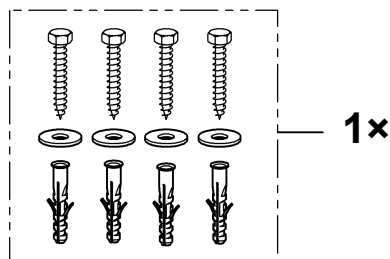
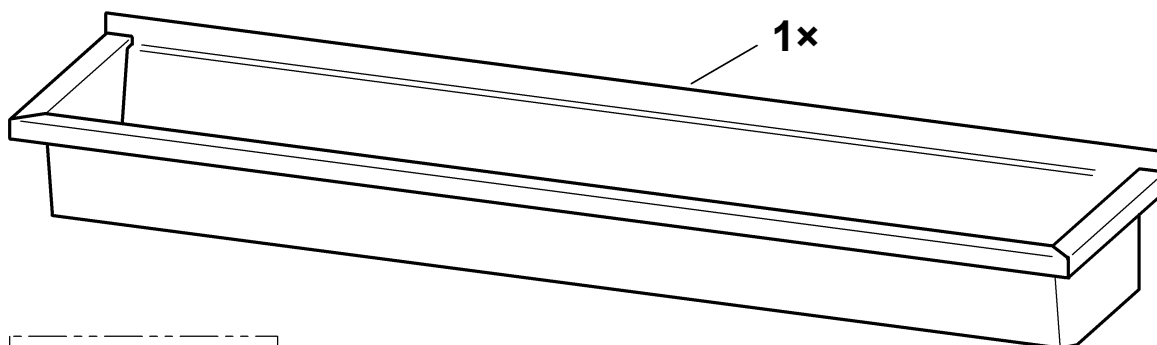

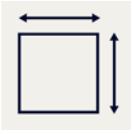

# PL6

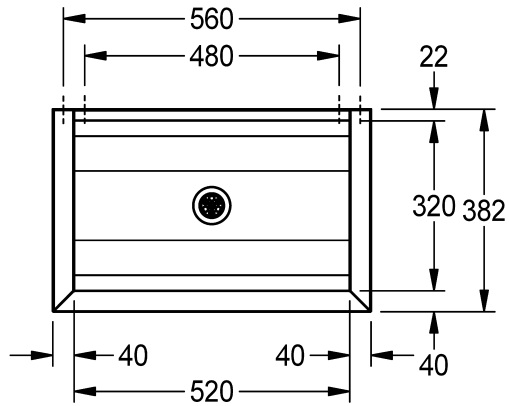
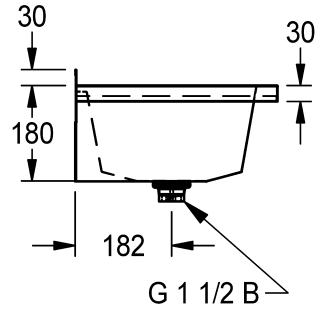
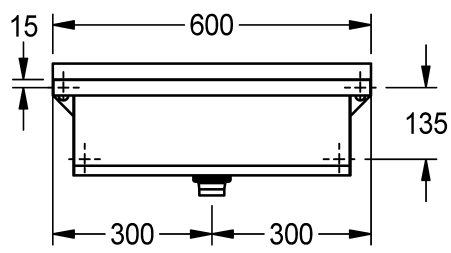

---

# PL8

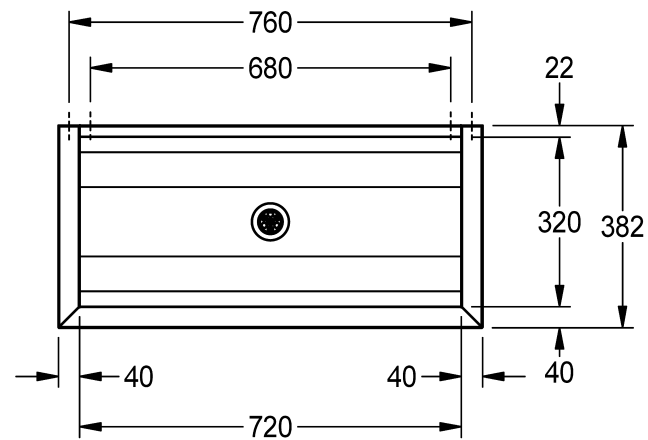
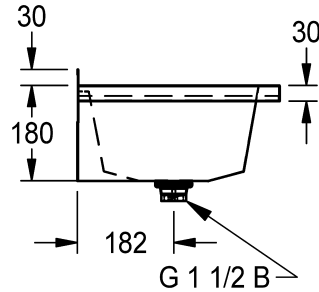
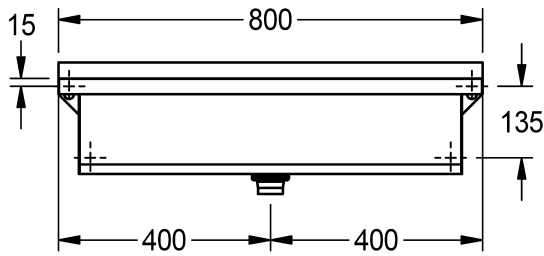

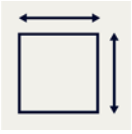

### PL10

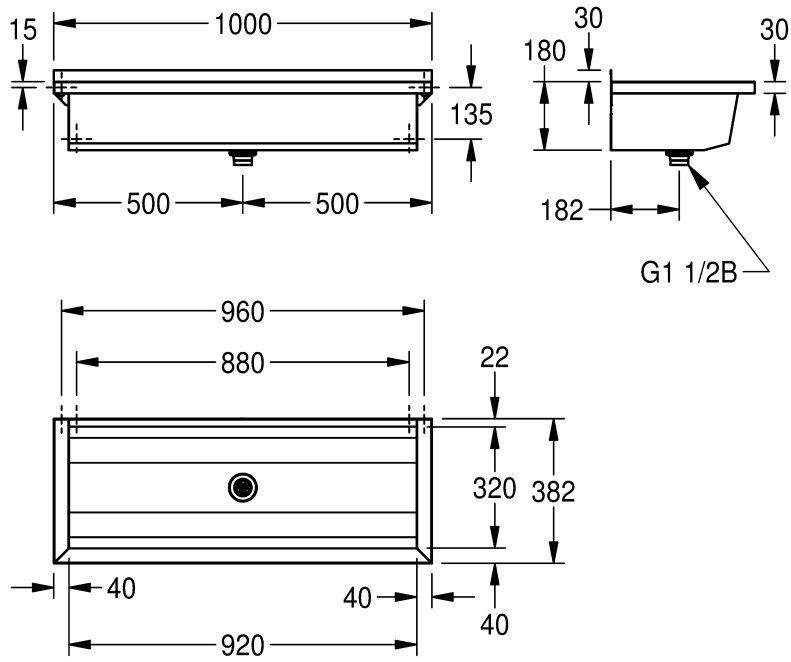

---

### PL12

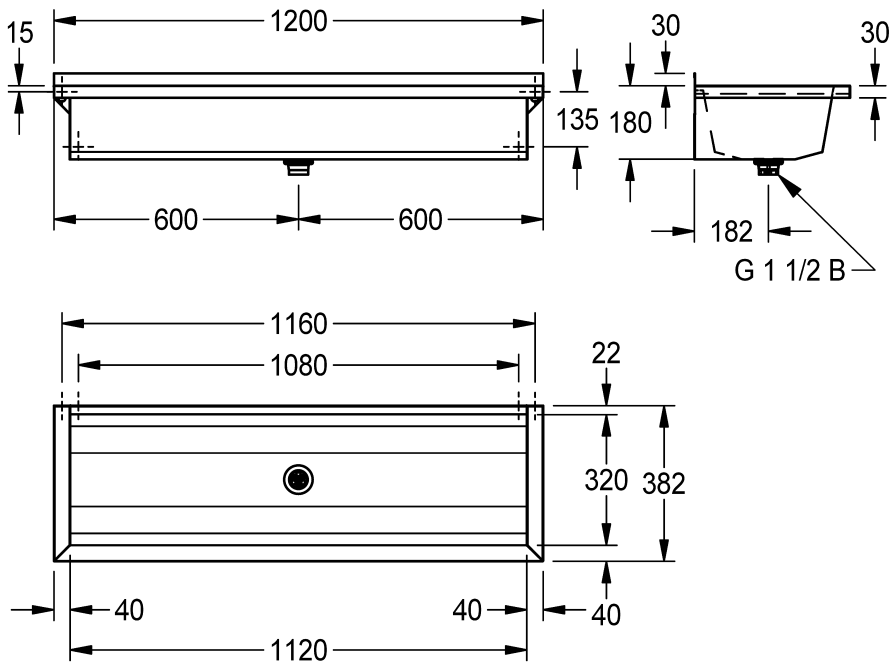

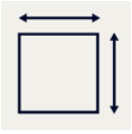

### PL14

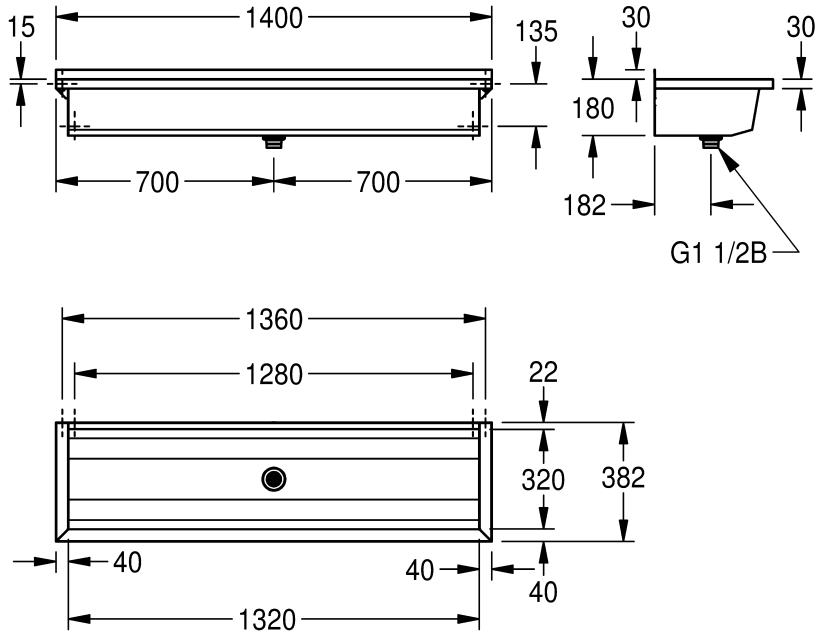

### PL16

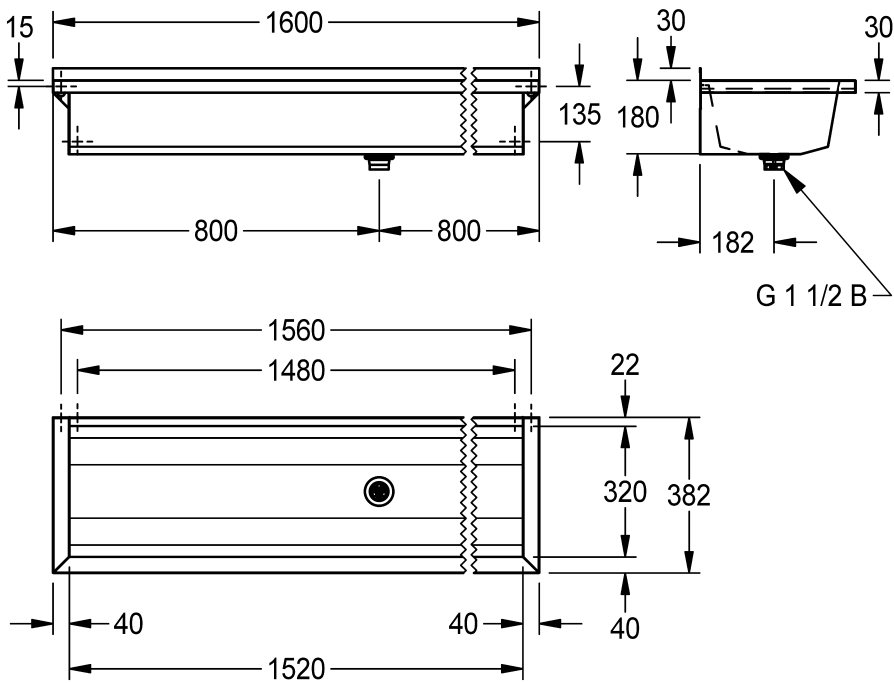

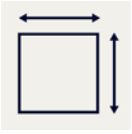

**PL18**

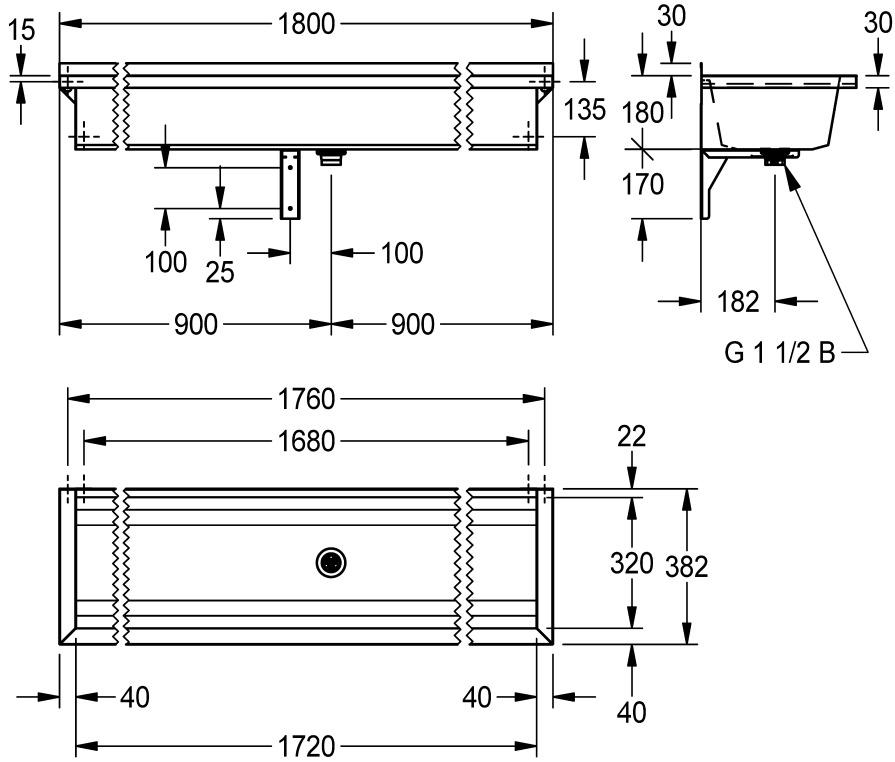

**PL21**

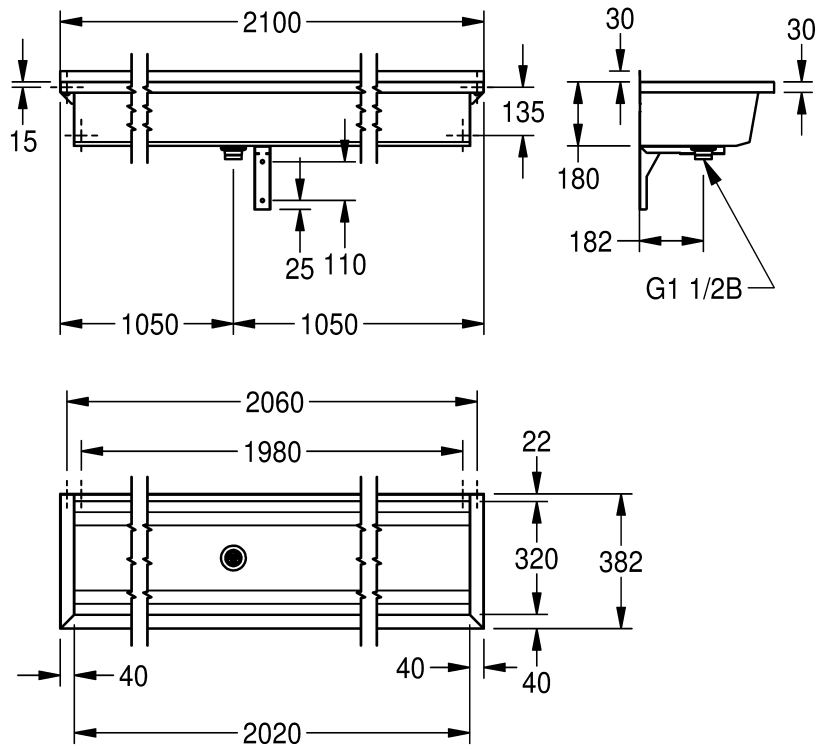

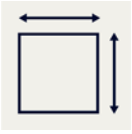

# PL24

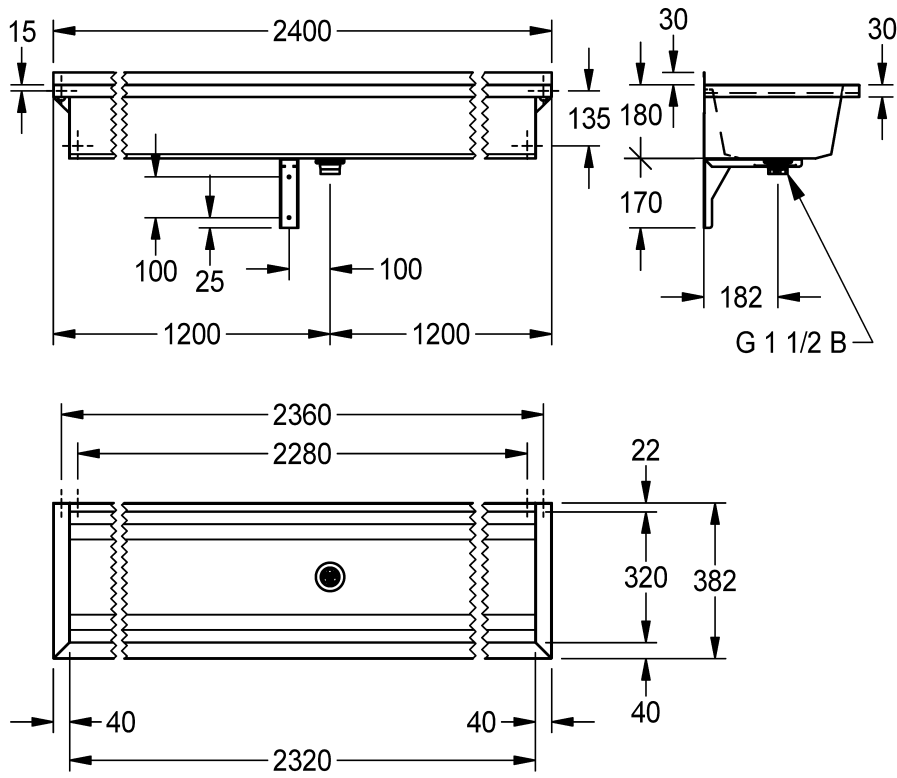

---

# PL28

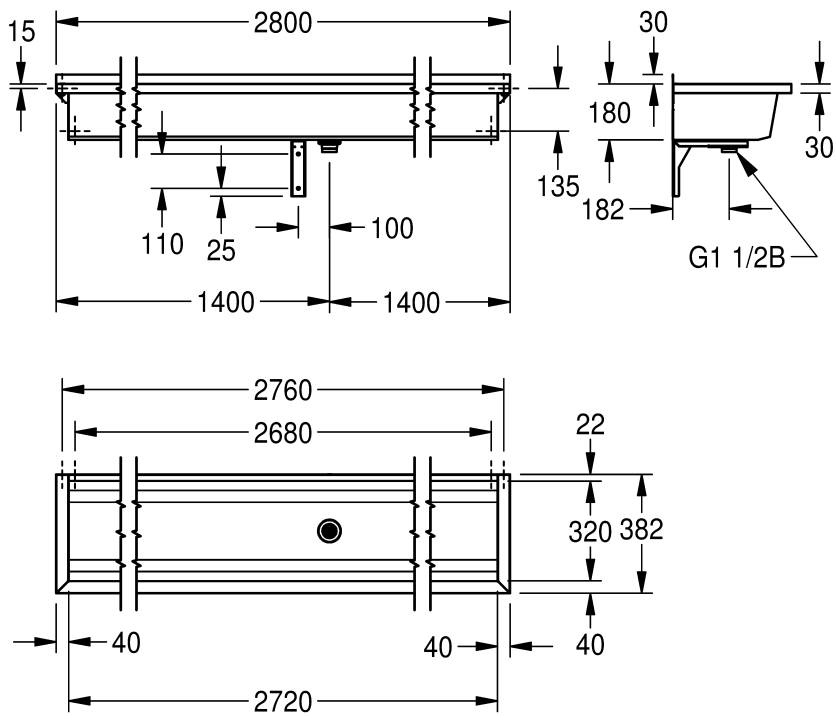

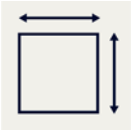

**PL30**

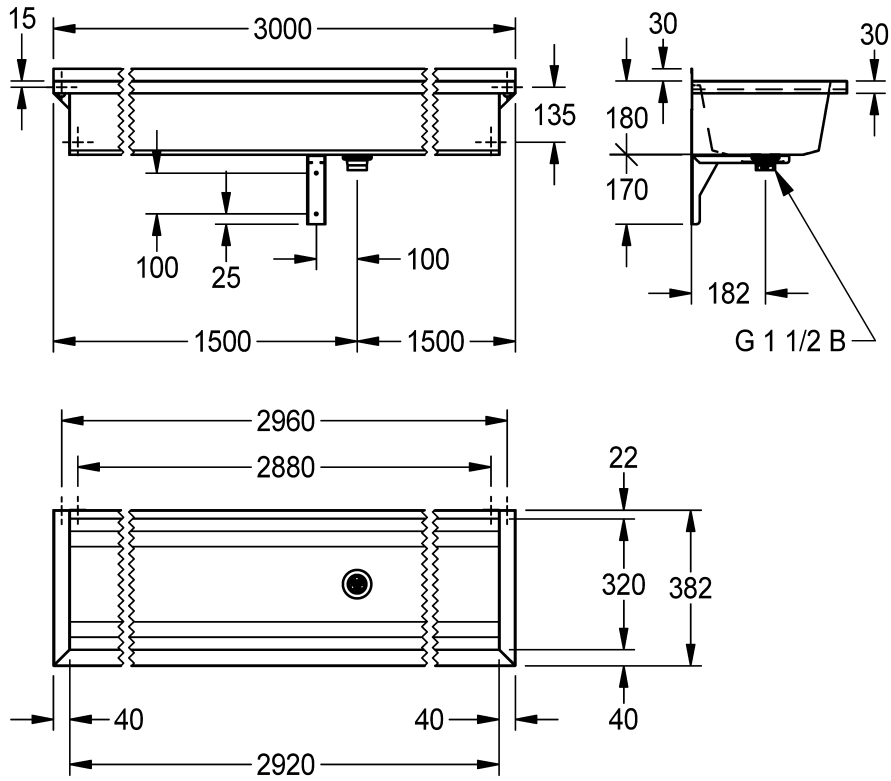

**PL18SU**

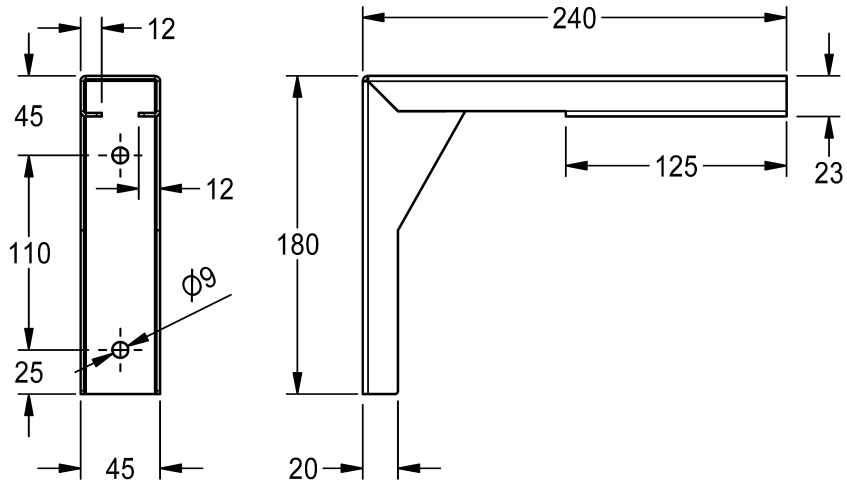

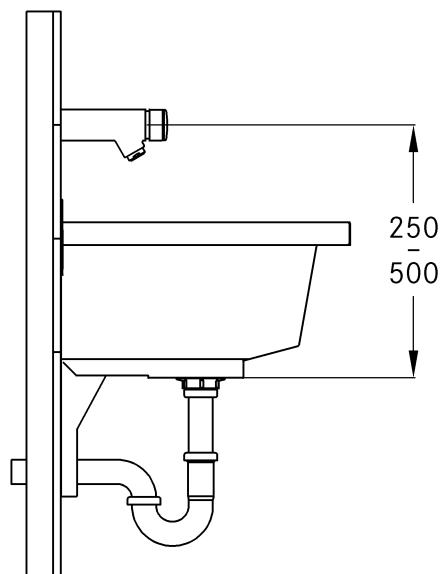
**EN**

## Installation and operating instructions

### Important notes

- Screws delivered with the product are adequate for concrete walls. For other kind of walls, please chose the adequate fixing material.

**DE**

## Montage- und Betriebsanleitung

### Wichtige Hinweise

- Die mitgelieferten Schrauben sind für Betonwände geeignet. Für andere Materialien wählen Sie bitte das passende Befestigungsmaterial.

**PL**

## Instrukcja montażu i obsługi

### Ważne wskazówki

- śruby dostarczone z produktem są przeznaczone do ścian betonowych. W przypadku mocowania w innych ścianach należy dobrać odpowiednie do nich materiały mocujące.

**SV**

## Monterings- och driftinstruktion

### Viktiga informationer

- Observera att skruvarna som medföljer produkten är lämpliga för betongväggar. Välj lämpliga fästmaterial vid andra typer av väggar.

**FR**

## Notice de montage et de mise en service

### Remarques importantes

- Les vis fournies avec le produit sont prévues pour des murs en béton. Pour les autres types de murs, veuillez choisir le matériel de fixation adapté.

**CS**

## Návod pro montáž a provoz

### Důležité pokyny

- Šroubky dodávané s výrobkem jsou vhodné pro betonové stěny. Pro jiné druhy stěn zvolte vhodný upevňovací materiál.

**ES**

## Instrucciones de montaje y servicio

### Indicaciones importantes

- Tenga en cuenta que los tornillos suministrados con el producto son adecuados para paredes de hormigón. Para otro tipo de paredes, elija el material de fijación idóneo.

**IT**

## Istruzioni per il montaggio e l'uso

### Avvertenze importanti

- le viti fornite con il prodotto sono adatte per pareti in calcestruzzo. Per altri tipi di pareti, si prega di scegliere il materiale di fissaggio adeguato.

**NL**

## Montage- en bedrijfsinstructies

### Belangrijke aanwijzingen

- De schroeven die met het product meegeleverd worden, zijn geschikt voor betonnen muren. Voor andere soorten muren, het geschikte bevestigingsmateriaal kiezen.

**FI**

## Asennus- ja käyttöohje

### Tärkeitä ohjeita

- Tuotteen mukana toimitetut ruuvit on tarkoitettu betoniseiniin. Valitse muihin seiniin asianmukaiset kiinnikkeet.

**RU**

## Инструкция по монтажу и вводу в эксплуатацию

### Важные указания

- Входящие в комплект поставки винты подходят для бетонных стен. Для других материалов выбирайте подходящий крепежный материал.

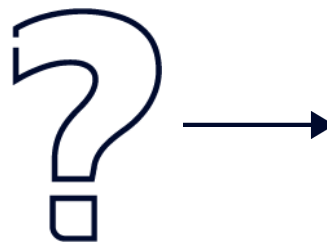
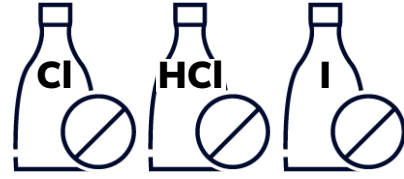

# 1. Montage

EN Installation  
FR Montage  
ES Montaje  
IT Montaggio

NL Montage  
PL Montaż  
SV Montering

CS Montáž  
FI Asennus  
RU Монтаж

**1**

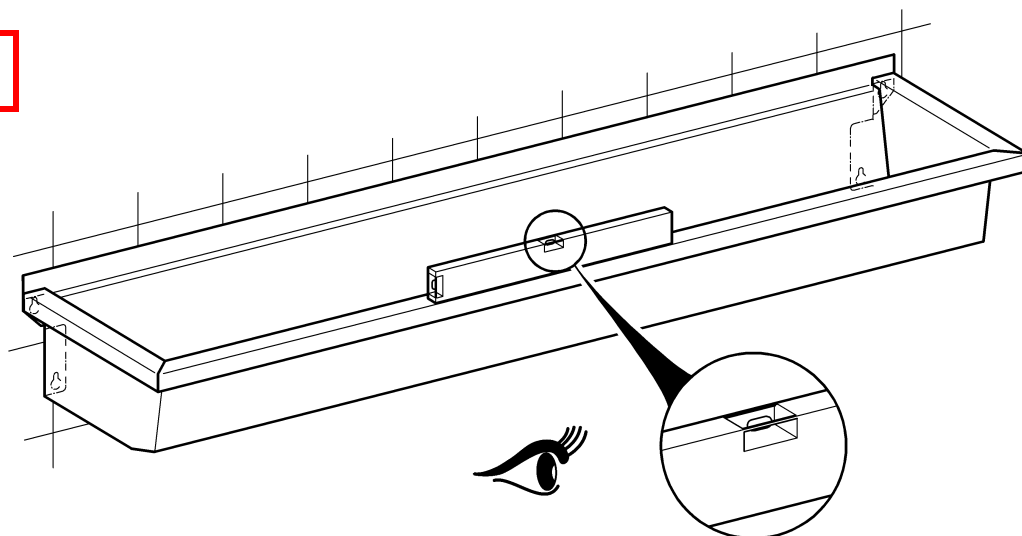

**2**

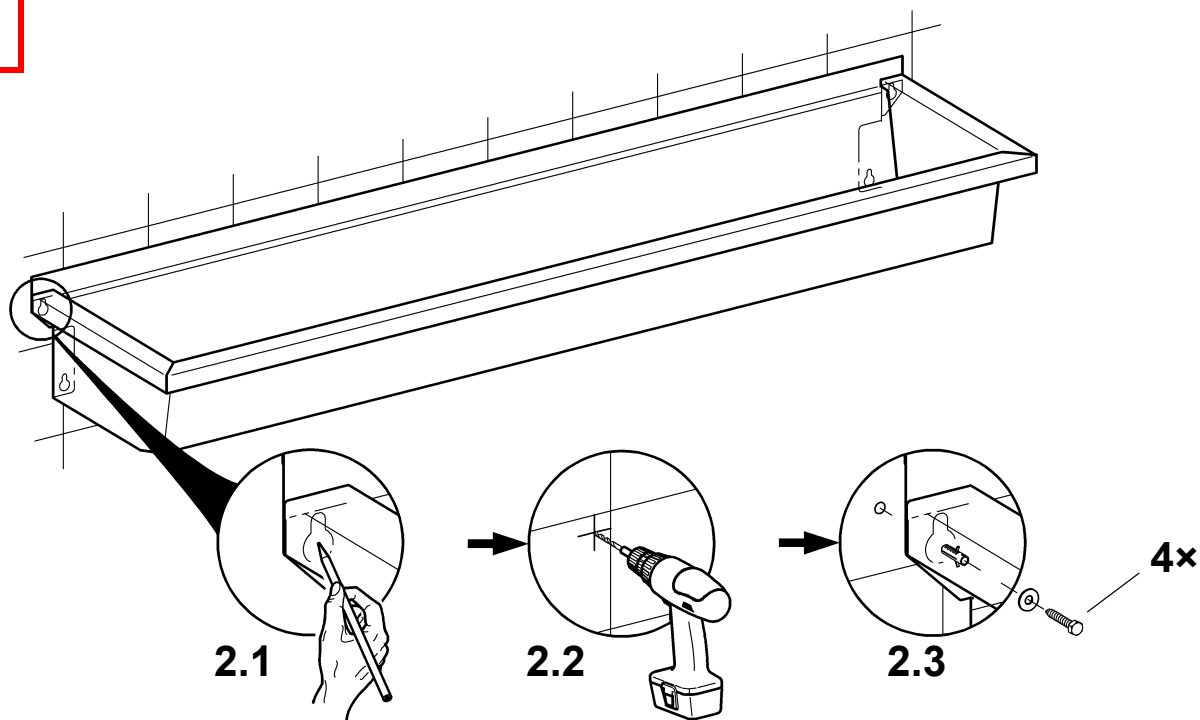

3

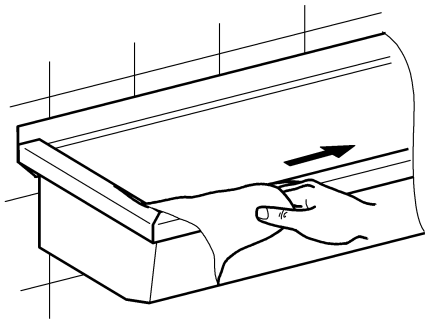

4

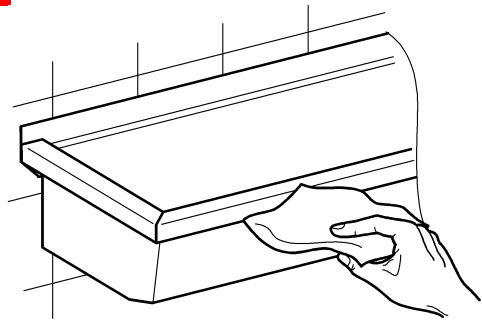

5

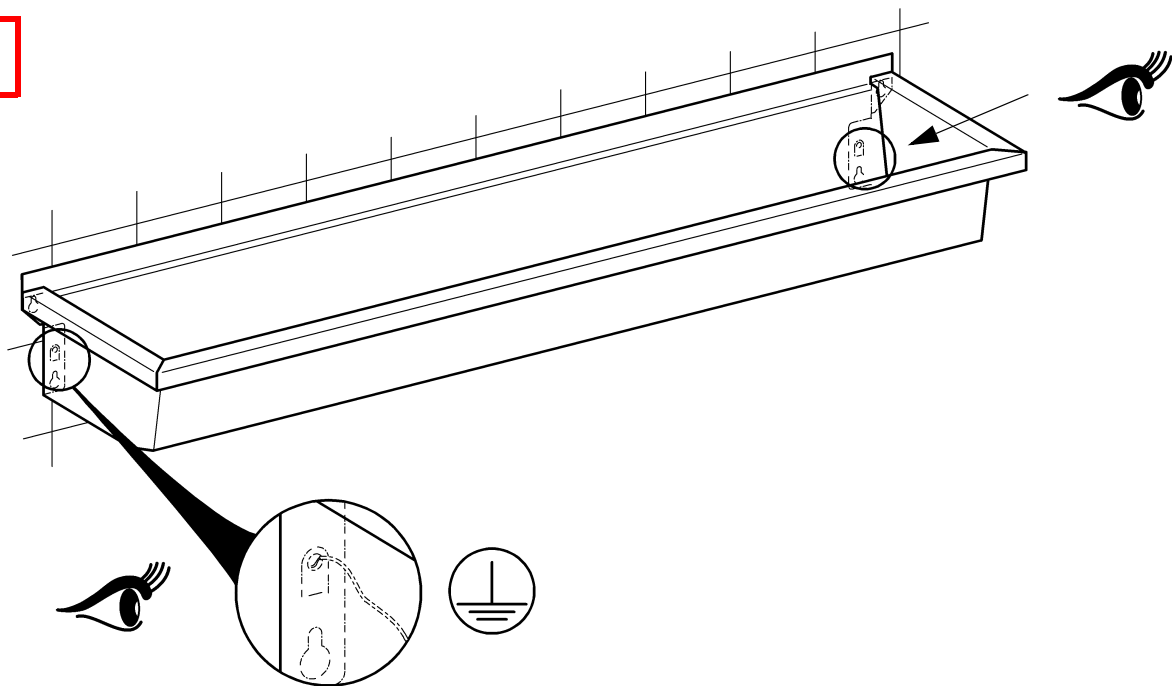

# 6 PL18, PL21, PL24, PL28, PL30

A

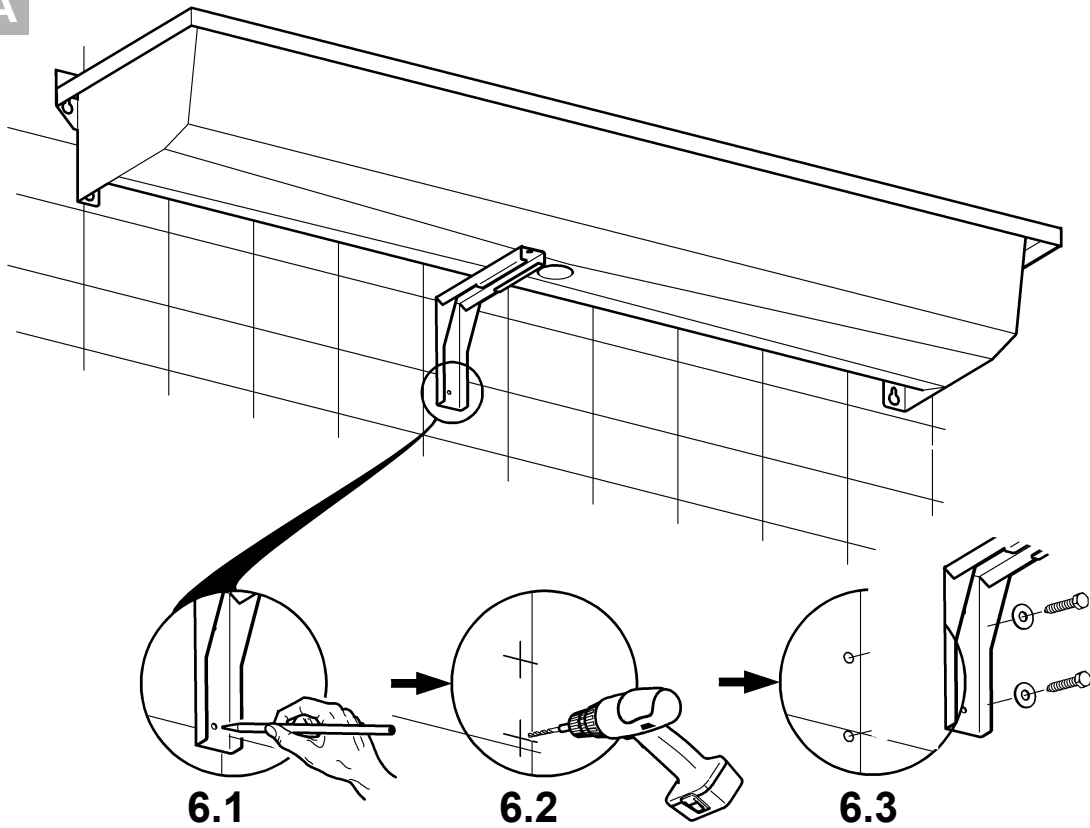

B

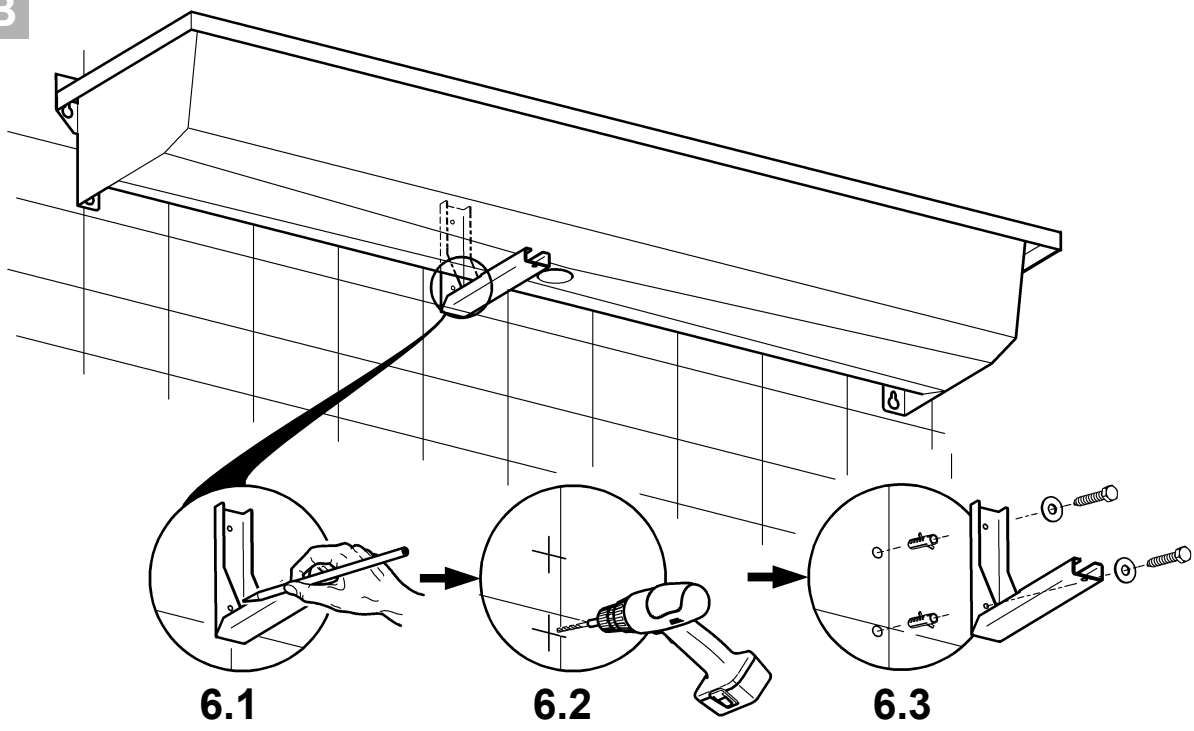

**7**

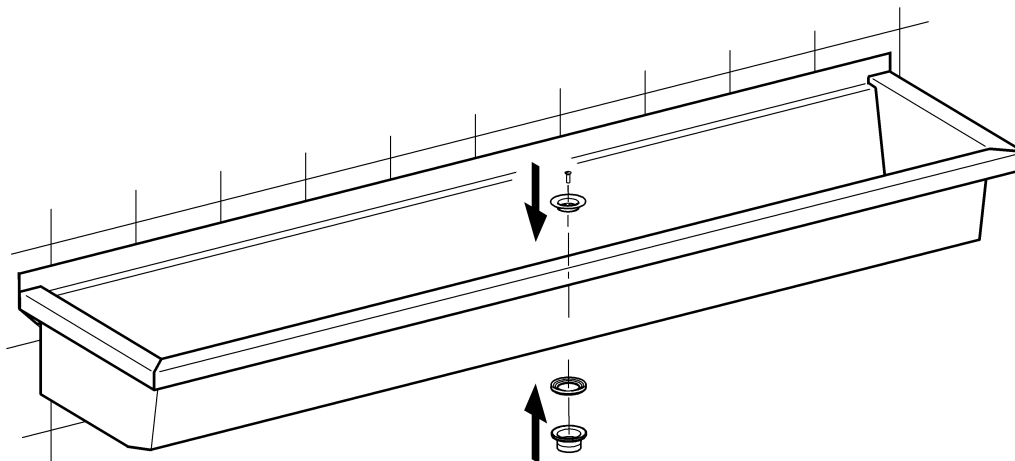

## 2. Ersatzteile

EN Replacement parts  
FR Pièces de rechange  
ES Piezas de recambio  
IT Pezzi di ricambio

NL Reserveonderdelen  
PL Części zamienne  
SV Reservdelar

CS Náhradní díly  
FI Varaosat  
RU Запчасти

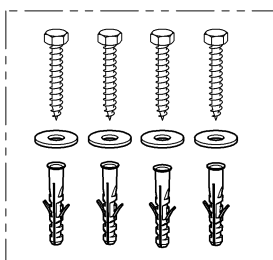

**2030047178**  
**EPL0001**

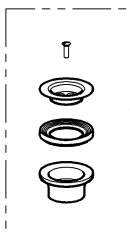

**2000103398**  
**ESIRX019**

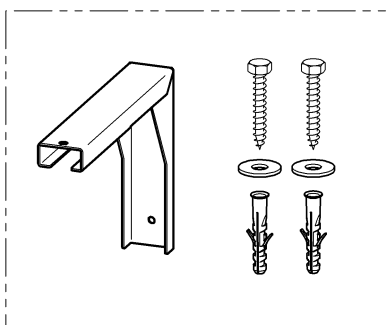

**2030043812**  
**PL18SU**

### 3. Zubehör

EN Accessories  
FR Accessoire  
ES Accesorios  
IT Accessori

NL Toebehoren  
PL Akcesoria  
SV Tillbehör

CS Příslušenství  
FI Lisävarusteet  
RU принадлежности

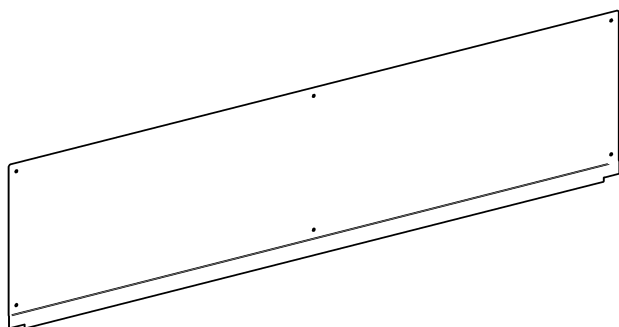

<b>PL6:</b>	2030043805 PL6SB	<b>PL18:</b>	2030043809 PL18SB
<b>PL8:</b>	2030043806 PL8SB	<b>PL21:</b>	2030054630 PL21SB
<b>PL10:</b>	2030053706 PL10SB	<b>PL24:</b>	2030043810 PL24SB
<b>PL12:</b>	2030043807 PL12SB	<b>PL28:</b>	2030053391 PL28SB
<b>PL14:</b>	2030049941 PL14SB	<b>PL30:</b>	2030043811 PL30SB
<b>PL16:</b>	2030043808 PL16SB		

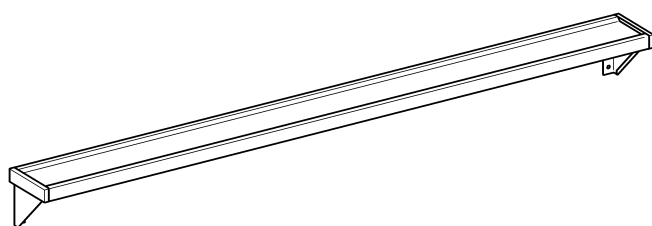

<b>PL6:</b>	2000056952 BXSV6	<b>PL18:</b>	2000056950 BXSV18
<b>PL12:</b>	2000056946 BXSV12	<b>PL24:</b>	2000100088 BXSV24
<b>PL16:</b>	2030046197 BXSV16	<b>PL30:</b>	2030046195 BXSV30



**478×119:**  
**2000101452**  
**TB60**

**728×119:**  
**2030046200**  
**TB80**

**Australia**

PR Kitchen and  
Water Systems Pty Ltd  
Dandenong South VIC 3175  
Phone +61 3 9700 9100

**Austria**

KWC Austria GmbH  
6971 Hard, Austria  
Phone +43 5574 6735 0

**Belgium, Netherlands &  
Luxembourg**

KWC Aquarotter GmbH  
9320 Aalst; Belgium  
Phone NL +31 (0) 492 728 224  
BE/LU +32 (0) 53 60 31 50

**Czech Republic**

KWC Aquarotter GmbH  
14974 Ludwigsfelde, Germany  
Phone +49 3378 818 309

**France**

KWC Austria GmbH  
6971 Hard, Austria  
Phone +33 800 909 216

**Germany**

KWC Aquarotter GmbH  
14974 Ludwigsfelde  
Phone +49 3378 818 0

**Italy**

KWC Austria GmbH  
6971 Hard, Austria  
Numero Verde +39 800 789 233

**Middle East**

KWC ME LLC Ras Al Khaimah,  
United Arab Emirates  
Phone +971 7 2034 700

**Poland**

KWC Aquarotter GmbH  
14974 Ludwigsfelde, Germany  
Phone +48 58 35 19 700

**Spain**

KWC Austria GmbH  
6971 Hard, Austria  
Phone +43 5574 6735 211

**Switzerland & Liechtenstein**

KWC Group AG  
5726 Unterkulm, Switzerland  
Phone +41 62 768 69 00

**Turkey**

KWC ME LLC Ras Al Khaimah,  
United Arab Emirates  
Phone +971 7 2034 700

**United Kingdom**

KWC DVS Ltd - Northern Office  
Barlborough S43 4PZ  
Phone +44 1246 450 255

KWC DVS Ltd - Southern Office  
Paignton TQ4 7TW  
Phone +44 1803 529 021

**EAST EUROPE**

Bosnia Herzegovina  
Bulgaria | Croatia  
Hungary | Latvia  
Lithuania | Romania  
Russia | Serbia | Slovakia  
Slovenia | Ukraine

KWC Aquarotter GmbH  
14974 Ludwigsfelde, Germany  
Phone +49 3378 818 261

**SCANDINAVIA & ESTONIA**

Finland | Sweden | Norway  
Denmark | Estonia

KWC Nordics Oy  
76850 Naarajärvi, Finland  
Phone +358 15 34 111

**OTHER COUNTRIES**

**KWC Austria GmbH**  
**6971 Hard, Austria**  
**Phone +43 5574 6735 0**

